



REV. N. 03 - 10.2022 - MIG STUDIO



SCM GROUP SPA
via Casale 450 - 47826 Villa Verucchio, Rimini - Italy
tel. +39 0541 674111 - fax +39 0541 674274
scm@scmgroup.com
www.scmwood.com



00L0447538C



formula *line*

The range of machines that completes and satisfies all the needs of any workshop.



SCM guaranteed quality

All the formula machines are guaranteed by SCM, reflecting their level of quality and reliability.



classical machines

6/23



circular saw / 6



planers / 12



spindle moulder / 20



band saws / 28



radial saws / 30



vacuum dust extractors / 36



clamp / 40

complementary machines

28/41

automatic machines

24/27



structuring/brushing machines / 24



cut-off saw / 32



horizontal mortiser / 34



dust extractors with bag / 38



feeders / 39

circular saw formula s 40

High quality construction
to perform professional work.

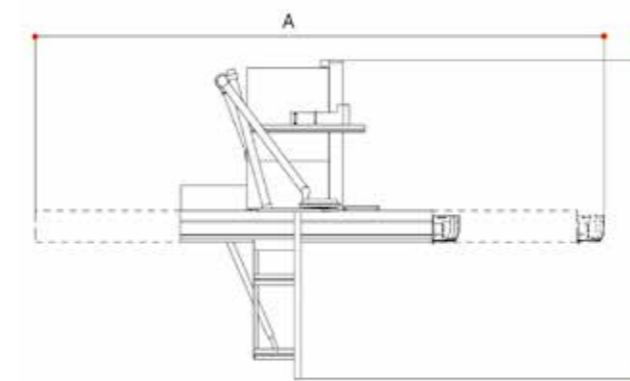

A with 3200 mm carriage	mm	7250
B with 1000 mm cutting width with rip fence	mm	4780
B with 1270 mm cutting width with rip fence	mm	5050
B with 1500 mm cutting width with rip fence	mm	5280

S Standard
O Option

formula		s 40
Squaring capacity	mm	3200
Stop on fence for squaring cuts extendable up to	mm	3200
Standard cutting width with rip fence	mm	1270
Main saw blade diameter (hole)	mm	400 (30)
Scoring blade diameter (hole)	mm	120 (20)
Max. saw blade projection from the table at 90°	mm	140
Max. saw blade projection from the table at 45°	mm	99
Saw blade speed	rpm	3700
Scoring blade speed	rpm	8500
Saw blade tilting	degrees	90 ÷ 45
Exhaust outlet diameter at base	mm	120
Exhaust outlet diameter on blade protection	mm	80 (60 NON CE version)
Motor power with direct start (standard)	kW	7
Motor power with automatic star-delta start (option)	kW	9
Standard features and main optional devices		
Automatic motor brake on main blade (only CE version)		S
Device for angular cuts		O
Device for angular cuts with self-adjustment of the stop position		O
Device for rip cuts		O
Overhead saw blade protection (optional device for NON CE version)		S
Cutting width on rip fence 1000 mm or 1500 mm		O
"M" version with 3 saw blade rotating speeds and powered unit lifting and tilting		O
"M Plus" version with 3 saw blade rotating speeds, automatic rip fence, mobile control panel and 9 kW motor		O

circular saw operating groups

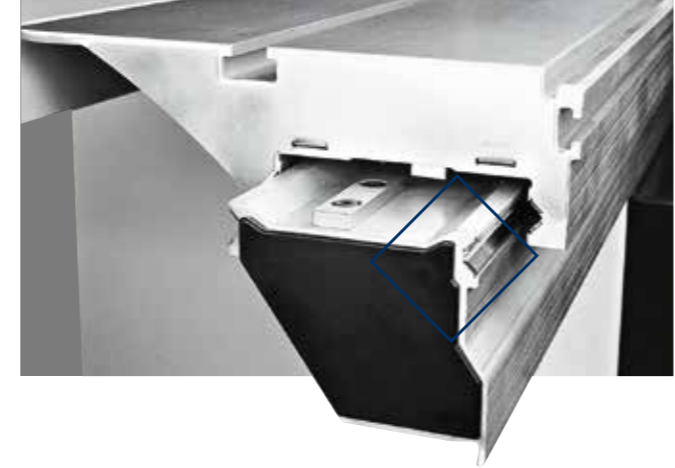

circular saw optional devices



Angular cutting device
equipped with:
- telescopic fence with two reversible stops
- preset for angle rapid selection

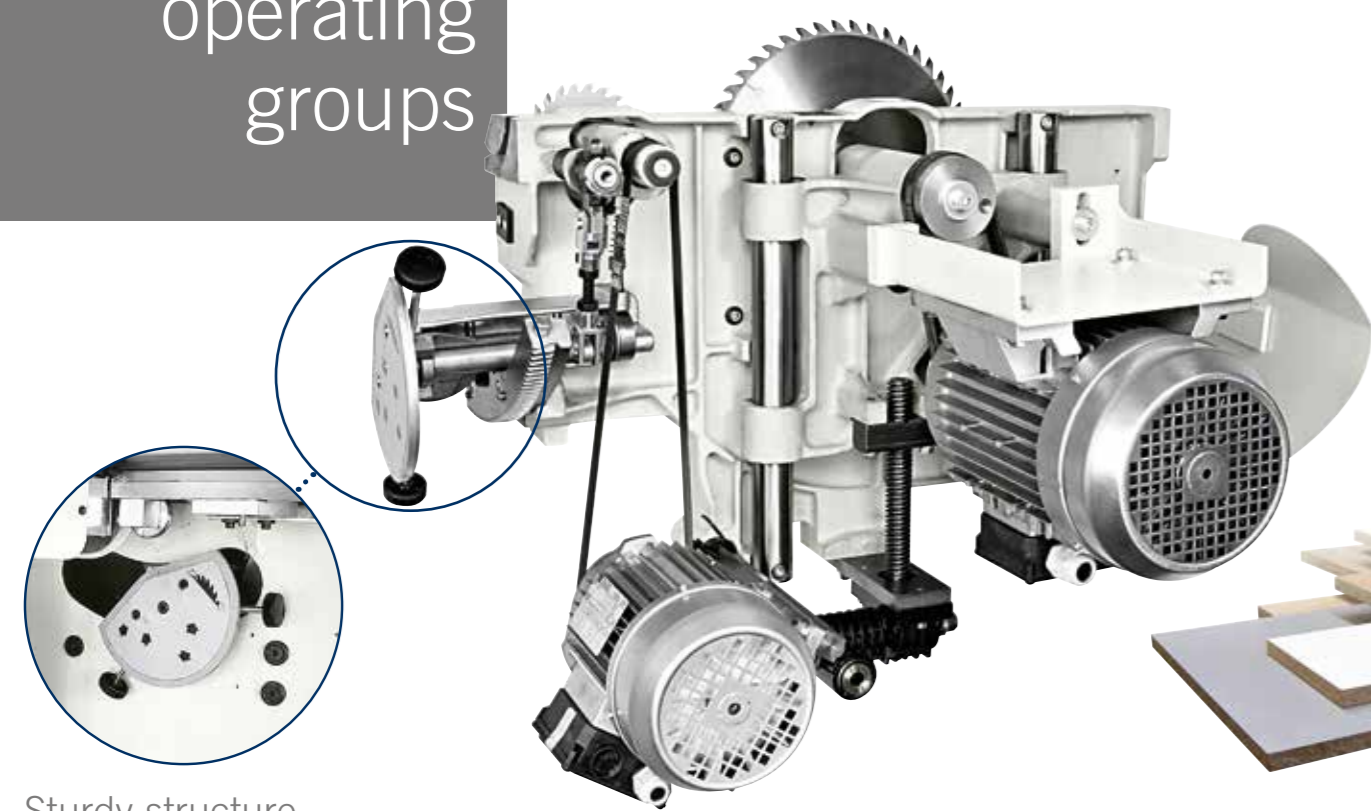

Sturdy structure
Saw unit

A large structure, an hardened cast iron work table and an innovative operating unit prevent vibration to ensure excellent finishing. The height adjustment on round guides ensures smooth movements even after years of use. The controls on the machine front and therefore in an easily accessible position by the operator guarantee a **further saving of time in the preparation process.**

Simple and effective
Scoring unit adjustment

The scoring unit is moved vertically and horizontally through a lever system which ensures the complete **absence of play.** This system also enables **quick positioning** thus limiting the need of sawing tests.

Smooth movement and sturdy support surface

Saw carriage
The circular saws carriage of the **formula line** utilizes a sliding system on aluminum stiff profiles with hardened steel guides using an exclusive method of mechanical fixing. This allows a straight line precision of +/- 0,05 mm along the entire carriage length. The **best precision** is guaranteed **overtime** even with intensive use and **without maintenance.**



Optimal support
Large squaring frame

It enables the squaring of panels up to 3200 x 3200 mm. It is fitted with a guide complete with two reversible stops and an idle roller to facilitate the loading of large panels. The guide also allows angular cutting up to 45°.

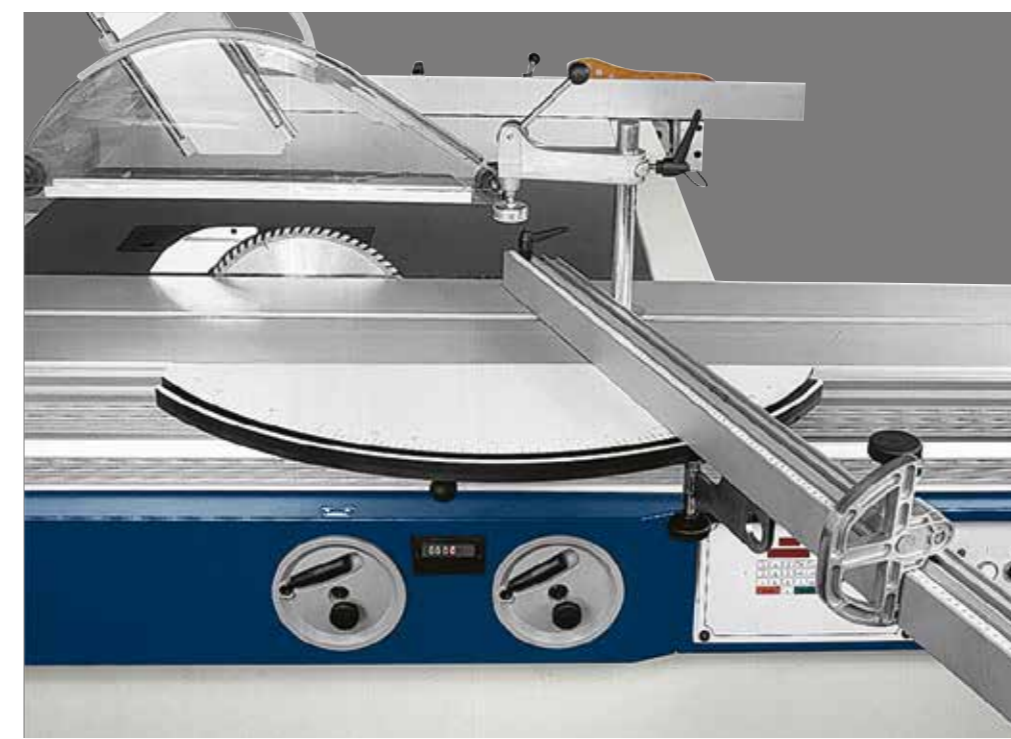

Device for angular cutting with automatic self-adjustment of the stop position with respect to the blade

Each time the cutting angle is adjusted so that the distance between the stop and the blade remains constant. This enables rapid set-up and reduces test cutting.



Rip cutting device
Particularly useful for trim cuts on long work pieces.

circular
saw
optional
devices



Electronic readout for rip fence position
Reading system on magnetic band and possibility of relative and micrometric adjustments.

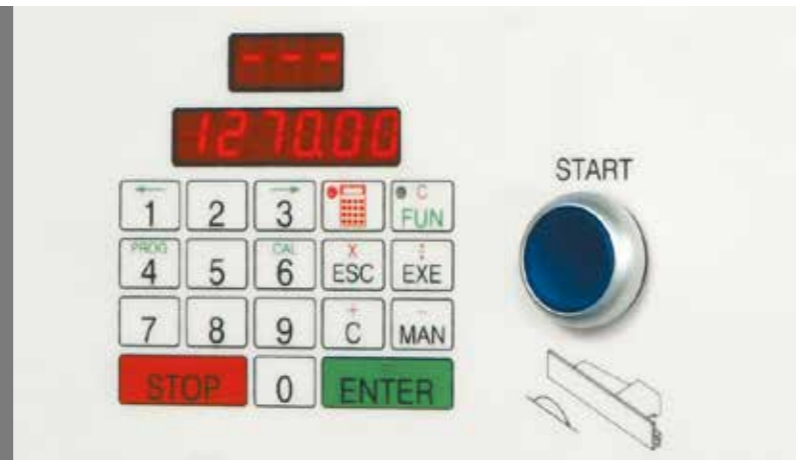

Powered rip fence with electronic positioning
Easy and precise positioning from numeric keyboard and by pushing a button, the fence rapidly reach the requested position which is visualized on the electronic display.



Three saw blade rotating speeds
The speed change can be made easily from the opening on the work table.
"M" and "M Plus" version



Overhead saw blade protection
Fitted in a tilted position it increases the useful cutting width to the rip fence and guarantees the maximum flexibility.



surface planers

formula f 2 formula f 1

Perfect surface, practical and ergonomic
Both models feature long, cast-iron work
tables and a large anodised aluminum
fence. An optimum **high-quality finish**
is guaranteed even on large size work
pieces.



formula f 1

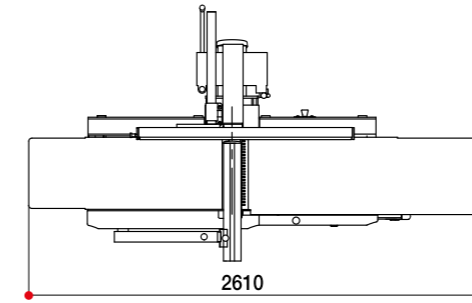

formula f 2

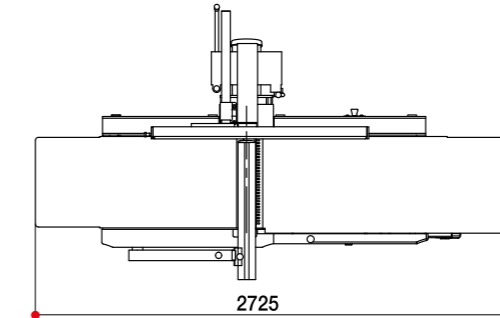

S Standard
O Option

formula		f 1	f 2
Working width	mm	410	520
Maximum removal	mm	8	8
Total length of work tables	mm	2610	2720
Dimensions of the surfacing fence	mm	1200x190	1200x190
Exhaust outlet diameter	mm	120	160
Motor power with direct start (standard)	kW	5	5
Motor power with star-delta start (option)	kW	-	7
Standard features and main optional devices			
Cutterblock with 4 knives		S	S
"Tersa" cutterblock with 4 throwaway knives		O	O
Additional overturning fence		O	O
"Xylent" cutterblock		O	O
Maintenance case for "Xylent" cutterblock		O	O
Automatic star-delta start		O	O

thicknessing planers

formula sp 1

formula sp 2

Sturdiness but also easy-to-use and precise, stylish with practical design, a wide range of applications.



formula sp 1

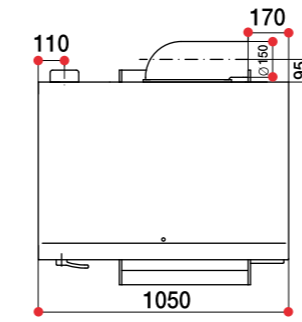

formula sp 2

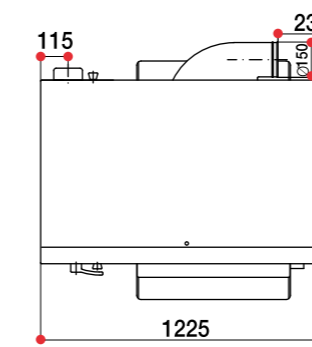

S Standard
O Option

formula		sp 1	sp 2
Working width	mm	520	630
Maximum removal	mm	8	8
Work table length	mm	1000	1000
Work table height	mm	250	300
Feed speed	m/min	5/8/12/18	5/8/12/18
Exhaust outlet diameter	mm	150	150
Motor power with manual star-delta start	kW	7	7
Standard features and main optional devices			
Outfeed rubber-coated steel roller		S	S
3rd top feed roller, rubber-coated & power driven		O	O
Work table with 2 idle rollers		O	O
1st powered sectioned steel feed roller		O	O
Cutterblock with 4 knives		S	S
"Tersa" cutterblock with 4 throwaway knives		O	O
Electric work table lifting		S	S
"Xylent" cutterblock		O	O
Maintenance case for "Xylent" cutterblock		O	O
Motor power with automatic star-delta start 9 kW		O	O
Automatic star-delta start		O	O

planers operating groups

formula line thicknessers are renowned for their strength. The operating unit with a four-knife cutter block guarantees a high-quality finish. An infeed roller with helical grooving and a rubber coated outfeed roller ensure efficient and smooth work piece feed.

High quality finish
Work tables made from ribbed cast-iron. The ribbed work tables structure with the feeding by means of a parallelogram mechanism on connecting rods always gives the same distance between the cutterblock and the table. This enables a quick and easy adjustment of the stock removal rates. The strong cast-iron structure of the cutter block with 4 knives grants optimal finish and absence of vibration.
formula f 1, formula f 2



Surfacing fence
The fence is mounted on a precision mechanism enabling accurate angle adjustment from 90° to 45°.

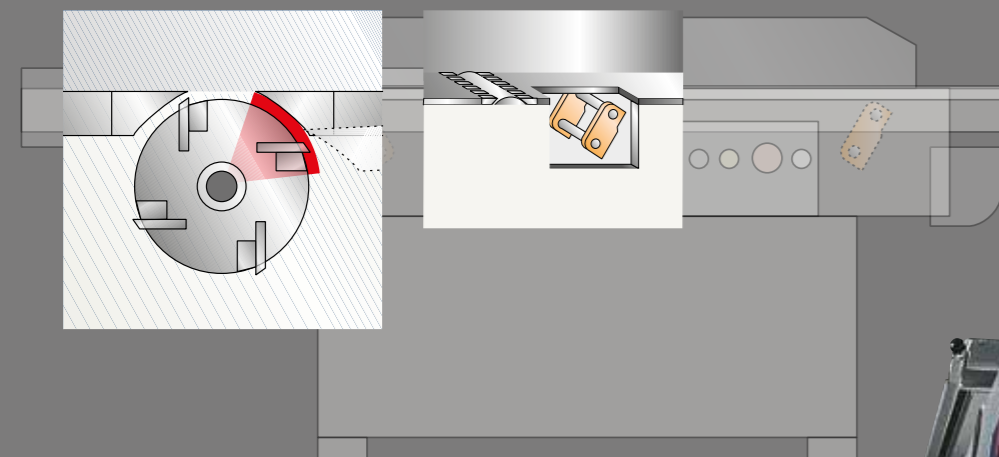

Sturdy structure with precision
Work table lifting
The ground, cast-iron work table is mounted on four recirculating ball screws simultaneously driven by a chain guaranteeing the best working stability. The machines are equipped with electric adjustment as standard feature; a solution offering ease-of-use, precise and rapid set-up.
formula sp 1, formula sp 2



Ease-of-use
Control system
All the controls are in an ergonomic position on the front of the machine such as the feed speed selector, the electric work height adjustment and a mechanical digital readout of working height.
formula sp 1, formula sp 2



planers
optional
devices



Simple and rapid
"Tersa" cutterblock with throwaway
knives

Automatic knives clamping by means of the centrifugal force ensures **safe and precise machining**. The system, without fixing screws makes knives substitution extremely fast.

"Xylent" cutterblock

The 3 spiralknives give an **exceptional finish**. **Reduced noise** during machining provides a more comfortable working environment. It also improves the dust extraction due to the production of very small chips. Each cutter has 4 tips which can be rotated into the cutting position when worn. Therefore increasing the production life of the cutter block before knives require replacement.



The thickening work table can be equipped with two rollers to **optimise work piece feed and throughput**.
formula sp 1, formula sp 2

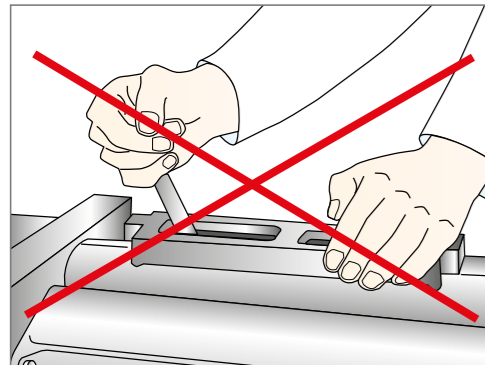

The specific knives fixing system to the cutterblock eliminates the setting up times.

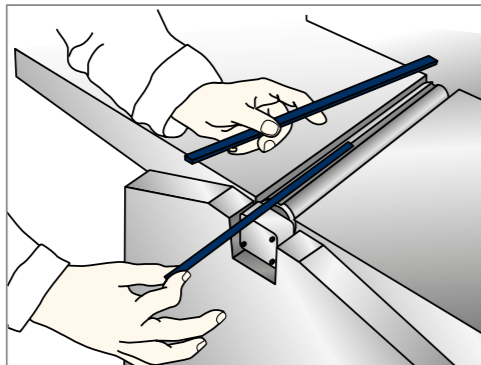

Easy cutter block knives introduction.

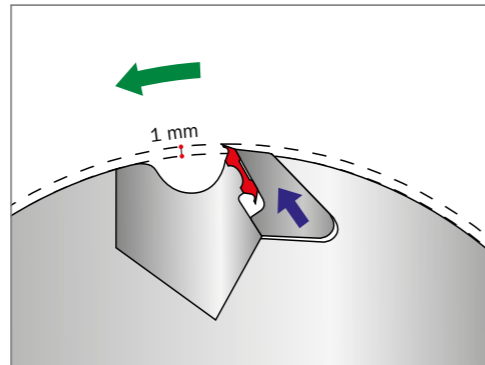

Knives self-locking at the machine starting thanks to the centrifugal force. The automatic projection of all knives is perfectly adjusted.

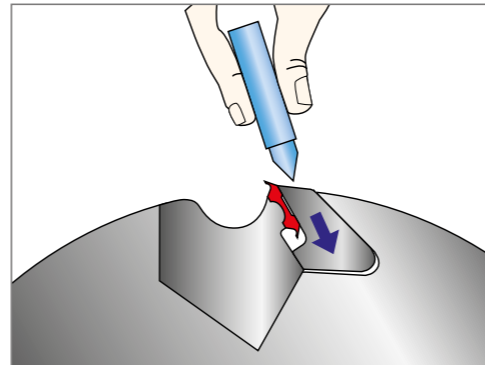

Quick knives substitution by gibs unlocking.



Maintenance case for
"Xylent" cutterblock

Complete with:

- 1 cleaning/degreasing liquid bottle for the resins cleaning
- 1 set dynamometric key
- 2 bit Torx
- 10 inserts
- 5 screws
- 1 brass bristle brush to clean the spindle with mounted in inserts
- 1 steel bristle brush to clean the inserts housings

Third feed roller

This is a powered, steel or rubber-coated roller designed to ensure perfect work piece feed with any type of wood.
formula sp 1, formula sp 2

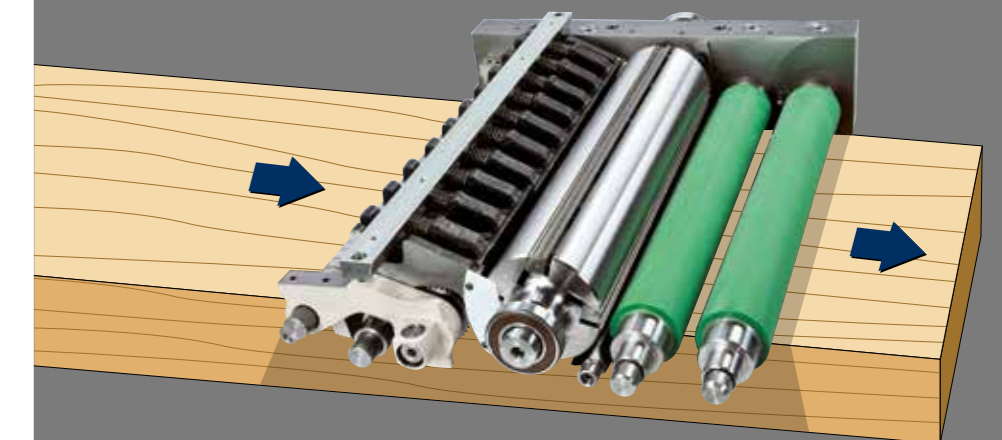

spindle moulder formula t 60f

High performance and very high reliability with precise and flexible operations and flexibility.
Rich equipment, for example the dedicated versions for moulding and tenoning.



formula t 60f

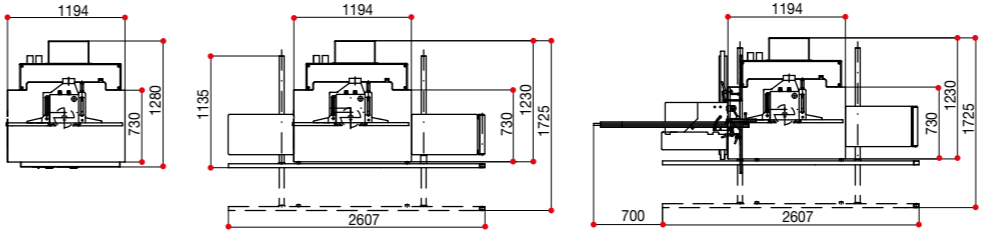

S Standard
O Option

formula		t 60f
Work table dimensions	mm	1200x730
Spindle height	mm	170
Max. tool diameter when profiling	mm	250
Max. tool diameter when tenoning	mm	350
Max. tool diameter when shaping	mm	160
Spindle stroke	mm	90
Spindle rotating speed	rpm	3000/4500/6000/8000/10000
Max. dimension of returning tool under table at 90°	mm	320x85
Exhaust outlet diameter on fence	mm	120
Exhaust outlet diameter behind the base	mm	120
Motor power with direct start	kW	5
Motor power with manual star-delta start (automatic start for USA/Canada version)	kW	7 (option)
Main options		
Carriage on the table for small tenoning operations		0
“LL” version for profiling operations		0
“T” version for tenoning operations (lateral carriage)		0
“TL” version for tenoning and profiling operations		0
Spindle fence with handwheel movement		0
Anodised aluminum spindle fences		0
Interchangeable spindle		0
Spindle reverse rotation		0

spindle moulder versions for tenoning and moulding



Simple working
Carriage on work table for small tenoning jobs
Ideal for tenoning of small work pieces for versions without sliding carriage. Mitre cuts with angles of a +/- 60°. on the work table are possible. Easy fitting and removal due to the fixing system on the work table.

spindle moulder optional devices

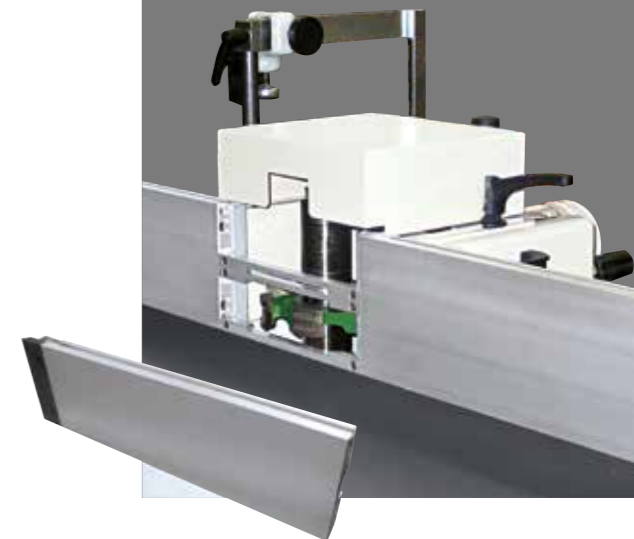

Anodised aluminium guides with "T"-shaped upper groove for insertion of stops during interrupted machining. It is complete with connecting bars for a maximum supporting surface area close to the tool.



Ideal for long work pieces "LL" version

The "LL" version is available with two side table extensions and an extractable front support table, for increased **safety and more precise machining of long and heavy profiles**. The cast-iron tables have a **ground surface to guarantee the maximum flatness**.



t 60f "TL"
*in CE version
(machine with options)*

Precision and stability in machining "T" and "TL" versions

The "T" or "TL" versions meet the special requirements of door and window machining. The table extension for large work pieces ("TL" version) provides a larger support surface. For precision tenoning, the machine has a sliding table which runs easily on axial bearings on a hardened, ground bar. The table has a large support surface and it is complete with a +/- 45° tilting fence and incorporates a cam lock clamping device. The tenoning version has special safety devices, such as arm guards and a dedicated hood which allows the use of tools with a diameter of up to 350 mm.

Very quick and simple Set-up Spindle fence with movement by handwheel

The entire fence has continuous linear adjustment by means of a single handwheel. This handwheel provides adjustment to the infeed and outfeed fence independently. Movements are displayed by mechanical digital readouts. The side handles make it easy to remove the guide from the work table.



Interchangeable spindle with MK4 fitting for using tools with different hole diameters thanks to the possibility of rapid changing of the spindle.

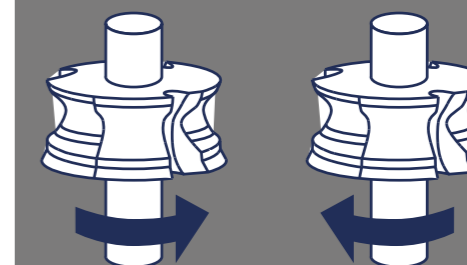

Spindle reverse rotation
for even more flexible use.

structuring/
brushing machines

formula str 32
formula str 62

Sturdiness and precision
are now available also for
the craftsman.



formula str 32

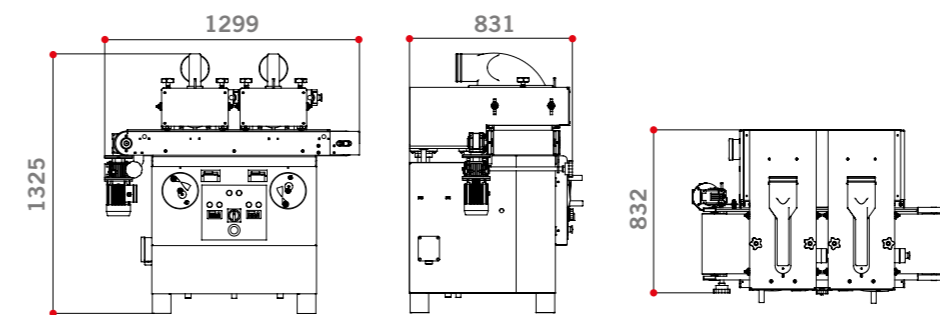

formula str 62

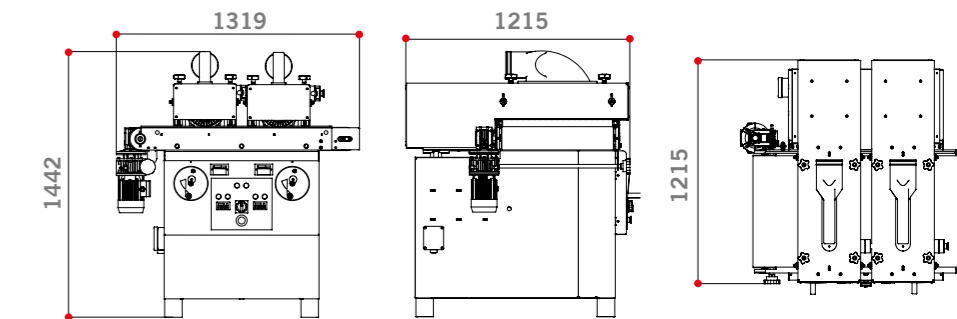

S Standard
O Option

formula		str 32r	str 32l	str 62r	str 62l
Working units		2	2	2	2
Working width	mm	300	300	600	600
Maximum working height	mm	300	300	300	300
Units motor power @ 50 Hz	kW	3	3	4	4
Feed belt motor power @ 50 Hz	kW	0,22	0,22	0,37	0,37
Exhaust outlets diameter	mm	2 x 150	2 x 150	2 x 150	2 x 150
Brush speed	rpm	1500	100 ÷ 1500	1500	100 ÷ 1500
Feed speed	m/min	3 ÷ 20	3 ÷ 20	3 ÷ 20	3 ÷ 20
Brush diameter	mm	190 / 190	230 / 230	190 / 190	230 / 230
Net weight	kg	440	440	750	750
Dimensions (LxDxH)	mm	1300x900x1300	1300x900x1300	1300x1200x1550	1300x1200x1550
main options					
Powered operating units lifting with digital readouts		0	0	0	0
Nylon brush (in place of the sanding brush, 300 mm width)		-	0	-	0
"Jigsaw" cross unit creating saw blade effect (first operating unit). The unit includes: - 25 steel strips - 1,5 kW motor controlled by inverter		0	0	0	0
Additional steel brush (wire 0,2 mm)		-	0	-	0
Additional steel brush (wire 0,3 mm)		0	0	0	0
Additional Tynex brush (60 grit)		-	0	-	0
Additional Tynex brush (80 grit)		0	0	0	0

structuring/
brushing machines
operating
groups

Perfect finish
The double operating unit allows to obtain the request finish in a single passage.



Effective extraction system
The large diameter of the exhaust outlets grants an optimal dust extraction.



Operating units lifting by means of handwheels and numerical readout.



Effective solutions
Feed speed variation with mechanical speed variator for a simple and reliable solution.



The best adherence thanks to the rubber belt with vertical grooves.



Rapid pressure rollers adjustment through dedicated knobs.

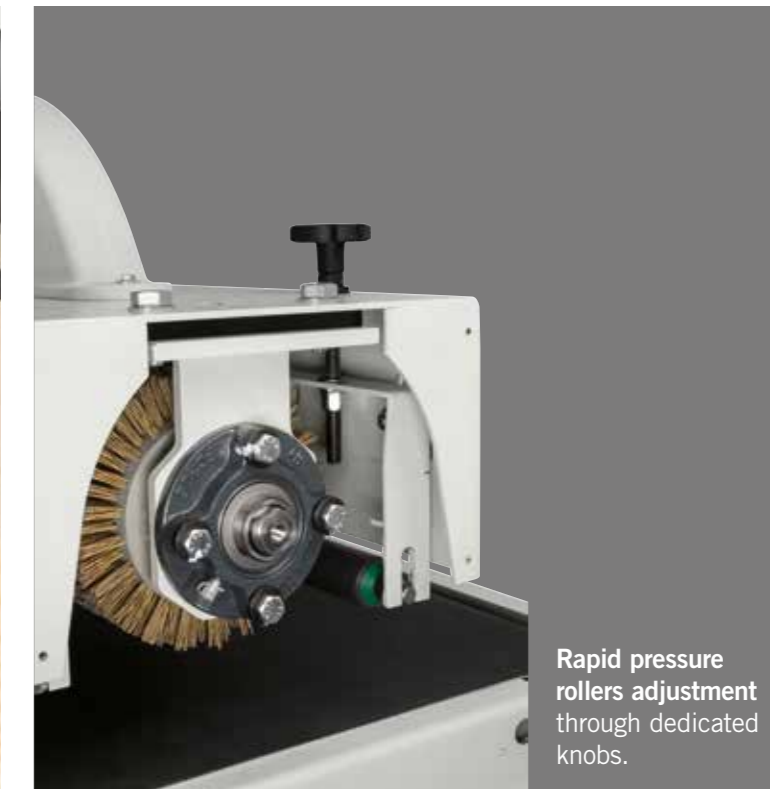

band
saws

formula s 440p
formula s 540p
formula s 640p
formula s 740p
formula s 840p
formula s 940p

Professional band saws, sturdy and extremely precise, for woodworking shops and craftsmen.

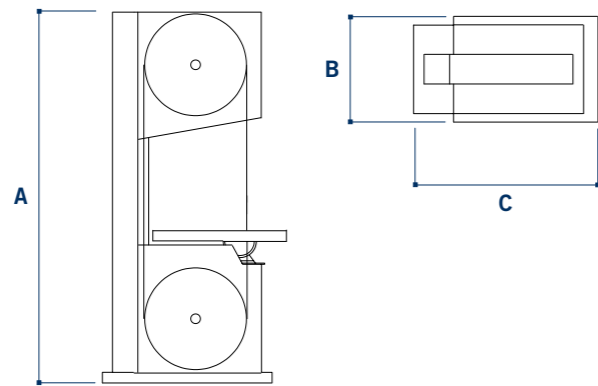

	s 440p	s 540p	s 640p	s 740p	s 840p	s 940p
A mm	1940	2100	2340	2395	2625	2860
B mm	420	520	600	710	800	800
C mm	805	940	1145	1265	1485	1590

formula		s 440p	s 540p	s 640p	s 740p	s 840p	s 940p
Work table dimensions	mm	420x578	520x720	600x885	710x1000	800x1160	800x1250
Cast iron saw wheels diameter	mm	440	540	640	740	840	940
Saw wheels width	mm	33	38	38	40	45	54
Max. cutting height	mm	440 (18")	500 (20")	600 (24")	450 (18")	540 (21")	560 (22")
Max. cutting width	mm	425	520	620	720	820	910
Work table tilting (CE)	mm	0° ÷ 45° (20°)	0° ÷ 45° (20°)	0° ÷ 45° (20°)	0° ÷ 45° (20°)	0° ÷ 45° (20°)	0° ÷ 45° (20°)
Min./max. blade dimensions	mm	6/30	6/35	8/35	10/40	10/45	12/50
Standard three-phase motor power S1 400 V 50 Hz	kW (Hp)	2,2 (3)	2,2 (3)	3 (4)	4 (5,5)	5,5 (7,5)	7,5 (10)
Standard three-phase motor power S1 220 V 60 Hz	kW (Hp)	3,6 (4,8)	3,6 (4,8)	3,6 (4,8)	5 (6,6)	6,7 (9)	6,7 (9)
Standard single-phase motor power S1 220 V 60 Hz	kW (Hp)	3,6 (4,8)	3,6 (4,8)	3,6 (4,8)	-	-	-
Exhaust outlets diameter	mm	2 x 120	2 x 120	2 x 120	2 x 120	2 x 140	2 x 140



band
saws
operating
groups



Perfect results
Blade guide
A perfect cut result is assured by the top and bottom high precision blade guides. Practical machines suitable also to perform straight and tilted cuts on wood, plastic and aluminum.



Solidity and sturdiness
Cast iron saw wheels
Very thick, cast iron wheels, as well as the work table, running on sealed for life ball bearings.

Safety first
Protections
Total safety machining with telescopic protections with rackwork to the blade.



radial saws
formula sr 650
formula sr 750
formula sr 900



radial saws
operating
groups



Long-lasting functionality
Column protection cover
The mechanisms of which the machine is equipped, as the protection cover on the arm column support, protect the mechanical parts from dust, guaranteeing the best operation over time.



Precision and smoothness
Carriage with 8 bearings
The 8 sliding bearings on the guides grant the best carriage smoothness and an optimal support for a perfect cutting result.



Absolute safety
Blade guard
It guarantees the absolute operator's safety.



Maximum cutting precision
Cast iron arm with steel interchangeable guides
The cast iron structure provides the arm the maximum solidity and rigidity for the maximum cutting precision. The interchangeable sliding ways allow the operator a simple and rapid replacing, in case of wear, without direct intervention on the arm.

formula		sr 900	sr 750	sr 650
Blade diameter	mm	400	350 ÷ 400	350 ÷ 400
Blade tilting		-45° ÷ +45°	-45° ÷ +45°	-45° ÷ +45°
Max. cutting depth with 90°/45° blade (* 400 mm blade diameter available as an option)	mm	120/83	120/83*	120/83*
Max. cross-cut capacity	mm	900 x 20	750 x 20	640 x 20
Three-phase motors power starting from	kW/Hz	4 (4) / 50 (60)	3 (3) / 50 (60)	3 (3) / 50 (60)

cut-off saw formula cut 350



cut-off saw operating groups



The best cleaning

Exhaust outlets

The exhaust outlets positioned near the dust evacuation areas ensure a fully cleaning of the working environment.



Absolute safety

Blade guard

The blade guard and the other operator's protection systems, as the bi-manual hand-safety control, allow to operate with absolute safety.



Smart solutions

Stops and pneumatic positioning

The machine is equipped with intelligent solutions as the optional stops and the pneumatic positioning.

formula		cut 350
Work table height	mm	800
Blade diameter	mm	350
Max. cross-cut capacity	mm	210 x 30
Max. working pressure	bar	8
Air consumption	NI/cycle	6
Exhaust outlets diameter	mm	80
Three-phase motor power	kW /Hz	3 (3) / 50 (60)

horizontal mortiser as 16



formula		as 16
Work table dimensions	mm	287 x 550
Longitudinal stroke	mm	200
Vertical stroke	mm	160
Transversal stroke	mm	125
Tool spindle diameter	mm	1 ÷ 16
Spindle speed	rpm	3000

horizontal mortiser operating groups



Solidity and manageability

Cast iron structure and sliding on cylindrical bars

Solidity and easy to handle with the cast iron strong structure which easily moves on cylindrical sliding bars.

Ease-of-use

Hand-wheel and levers

Easy movement of the boring head due to the practical control by hand-wheel and levers.

vacuum dust
extractors

formula vfp 200
formula vfp 250
formula vfp 300
formula vfp 350
formula vfp 350x



formula		vfp 200	vfp 250	vfp 300	vfp 350	vfp 350x
Nominal air flow @ 20 m/s	m ³ /h	2262 (1331 CFM)	3534 (2080 CFM)	5089 (2995 CFM)	6927 (4077 CFM)	7127 (4195 CFM)
Static pressure	Pa	2563	2451	2587	2543	3347
Max. air flow@ 20 m/s	m ³ /h	3000 (1770 CFM)	4900 (2884 CFM)	6000 (3531 CFM)	8500 (5000 CFM)	10000 (5886 CFM)
Exhaust outlet diameter	mm	200	250	300	350	350
Filter type		sleeves	sleeves	sleeves	cartridge	cartridge
Filter surface area	m ²	13,8	22,4	30	73	73
Chip volume	litres	2 x 165	2 x 165	3 x 165	3 x 165	3 x 165
Dimensions (LxDxH)	mm	2296x830x2050	2351x1058x2361	3000x1058x2361	3129x1058x2361	3129x1058x2361
Three-phase motor power	kW (Hp)	3 (4)	7,5 (10)	7,5 (10)	11 (14,7)	15 (20)

dust extractors

with bag

formula eco 350q

formula eco 350t

formula eco 300d

formula eco 300s

formula eco 300sk



formula		eco 350q	eco 350t	eco 300d	eco 300s	eco 300sk
Bags		4	3	2	1	1
Maximum fan air flow capacity	m ³ /h	4560	4560	3900	2550	2550
Fan diameter	mm	356	356	305	300	300
Exhaust outlets attachments		4	4	3	2	2
Exhaust outlets diameter	mm	100	100	100	100	100
Bags diameter	mm	1850	1850	1300	900	900
Bags capacity	m ³	0,79	0,59	0,43	0,15	0,15
Motor power	kW (Hz)	5 (50)	3,7 (50)	2,2 (50)	1,5 (50)	1,5 (50)

feeders

formula feed 48

feed 48 feeder with 4 rollers complete with stand

formula feed 38

feed 38 feeder with 3 rollers complete with stand

formula feed 4i

feed 4i feeder with 4 rollers with inverter complete with stand



formula		feed 38	feed 48	feed 4i
Rollers number		3	4	4
Feed speed	m/min	2/4/5,5/7/11/13/16,5/33	2/4/5,5/7/11/13/16,5/33	2 ÷ 22
Rollers diameter	mm	120	120	120
Rollers width	mm	60	60	60
Rollers excursion	mm	18	18	18
Three-phase motor power	kW (Hz)	0,75 (50)	0,75 (50)	0,50 (50)

clamp formula clamp 2500



clamp operating groups



formula		clamp 2500
Working dimensions	mm	2500 x 1800
Stroke of vertical hydraulic cylinders	mm	150
Thrust of each vertical hydraulic cylinders	kg	1270
Stroke of horizontal hydraulic cylinders	mm	120
Thrust of each horizontal hydraulic cylinder	kg	770

Ease-of-use Hydraulic cylinders

The simple and rapid vertical beams positioning system allows a very simple hydraulic cylinders adjustment.

Solidity and sturdiness Lower cast iron supports

Even more machine sturdiness with the lower cast iron supports.

Pressure under control Control panel

The hydraulic cylinders pressure is controlled by practical levers and a control panel which is equipped with a valve with reading monometer and a locking cock for the cylinders pressure maintaining. The process is always under control.



scm | service

WE'LL GO THE EXTRA MILE FOR YOU

SCM OFFERS A FULL RANGE OF **HIGHLY SPECIALISED SERVICES** WITH A QUALITY AND RELIABILITY THAT STEM FROM 70 YEARS OF EXPERIENCE IN THE INDUSTRY.

From installation and production start-up to services and maintenance. From training to the supply of specific original spare parts: **we provide solutions designed around you!**





CONTACT

SCM SERVICE
Via Emilia 77 - 47921 Rimini - Italy
tel. +39 0541 700100
scmservice@scmgroup.com
www.scmwood.com

SCM SPAREPARTS
Via Casale, 450 - 47826 - Villa Verucchio (RN) - Italy
tel. +39 0541 674111
spareparts@scmgroup.com
www.scmwood.com



My Scm

 <p>SERVICE AND MAINTENANCE</p> <ul style="list-style-type: none"> • Remote support • Scheduled maintenance contracts • Warranty extension 	 <p>TRAINING SERVICE</p> <ul style="list-style-type: none"> • Courses for machine operators • Software and programming courses • Training in production start-up
 <p>SPARE PARTS</p> <ul style="list-style-type: none"> • Recommended spare parts list • E-shop • Interactive spare-parts catalogues • Repairs on electronic parts, glue tanks and electro-spindles 	 <p>DIGITAL SERVICES</p> <ul style="list-style-type: none"> • Maestro Connect - IoT platform to be constantly connected with your machines • Smartech - assistance with augmented reality • My Scm portal - opening of service ticket and single point of access to the apps and Services tools

THE STRONGEST WOOD TECHNOLOGIES ARE IN OUR DNA

SCM. A HERITAGE OF SKILLS IN A UNIQUE BRAND

70 years of success gives SCM the centre stage in woodworking technology. This heritage results from bringing together the best know-how in machining and systems for wood-based manufacturing. SCM is present all over the world, brought to you by the widest distribution network in the industry.

70 years history

3 main production sites in Italy

300.000 square metres of production space

20.000 machines manufactured per year

90% export

20 foreign branches

400 agents and dealers

500 support technicians

500 registered patents

In **SCM's DNA** also strength and solidity of a great Group. The SCM Group is a world leader, manufacturing industrial equipment and components for machining the widest range of materials.

SCM GROUP, A HIGHLY SKILLED TEAM EXPERT IN INDUSTRIAL MACHINES AND COMPONENTS

INDUSTRIAL MACHINERY

Stand-alone machines, integrated systems and services dedicated to processing a wide range of materials.



WOODWORKING TECHNOLOGIES



TECHNOLOGIES FOR PROCESSING COMPOSITE MATERIALS, ALUMINIUM, PLASTIC, GLASS, STONE, METAL

INDUSTRIAL COMPONENTS

Technological components for the Group's machines and systems, for those of third-parties and the machinery industry.



SPINDLES AND TECHNOLOGICAL COMPONENTS



ELECTRIC PANELS



METALWORK



CAST IRON

scm | is more
woodworking technology