

olimpic range

automatic edge banders for the furniture industry

edge banders, sizing edge banders



REV. N. 01 - 05.2020



SCM GROUP SPA
via Casale 450 - 47826 Villa Verucchio, Rimini - Italy
tel. +39 0541 674111 - fax +39 0541 674274
scm@scmgroup.com
www.scmwood.com



00L0530731C



**OLIMPIC
YESTERDAY, TODAY, TOMORROW**



**FOREVER
BY YOUR SIDE**



EDGE BANDING, WHERE
IT ALL STARTED:
PROFESSIONAL, RELIABLE,
AFFORDABLE

SIMPLE



Maximum ease of use with all HMIs. **Maestro active edge**, an expert operator for optimal production.

SMART



Use of **EVA and polyurethane glue**, quick and easy glue change thanks to **SGP glue pot**.

Cutting and radius performed in a single operation automatically and without errors with the double-blade system of the K-2 end cutting unit.

A single operator needed to manage the entire edging process thanks to the panel return devices.

VERSATILITY



Trimming of **different edge thicknesses** with simple and fast set-up thanks to the multiprofile tools.

Productivity with rounding and trimming in a single operation thanks to the Round X rounding unit.

Panel processing with hinge holes coming from the nesting cycle.

TOP QUALITY



Perfect junction line with an excellent premilling of the panel and optimal glue spreading.

Cleaning and quality of the panel obtained with the use of specific liquids in combination with brushes and glue scraper.

“Zero” joint line and and gluing without glue thanks to AirFusion+ E technology.

AUTOMATIC



Fast changeover between two different edges with radius, thin and solid, automatically carried out by multiedge units with NC axes.

Automatic glue dosing with NC axis at the machining changeover, available with SGP glue pot.

DURABILITY



Durable over time thanks to consolidated and reliable technical solutions such as prismatic guides, large tracks and vibration-free structure.

OVERVIEW OF TECHNICAL FEATURES

TECHNOLOGICAL ADVANTAGES

HP version



R-HP Multiedge 2R trimming unit.

Multiedge units: rapid machining changeover between 2 different radii, infinite thin edges and solid wood.



RAS-HP Multiedge 2R edge scraping unit.



MAESTRO active edge:

an expert operator that guides you to produce quickly and without errors. 21,5" Touchscreen.



QMS-P Premelting device: the best available glue quality.



Perfect junction line and use of EVA and PUR glue thanks to the "SGP" glue tank.



ROUND X MULTIEDGE rounding unit with 2 motors and NC axes for an automatic set up.



Extraordinary level of finishing quality with AirFusion⁺

OVERVIEW OF TECHNICAL FEATURES

TECHNOLOGICAL ADVANTAGES



R-K trimming unit: rapid machining changeover between thin, thick and solid wood edges.



ROUND X 2-motor rounding unit: excellent quality of the panel with simultaneous rounding and trimming of the edge.



RC-N glue scraping unit: It eliminates any excess of glue in the joint between panel and edge.



RAS/K edge scraping unit: it eliminates the notches left by the tools on the plastic edges



K/SEL end cutting unit: optimal panel finishing thanks to the blade tilting.

HMI Startouch: a "touch" to use the machine.



RT-V premilling unit: a perfect joint line.



QMS-P premelting device: the best quality of glue available.



Extraordinary level of finishing quality with AirFusion+



Perfect junction line and use of EVA and PUR glue thanks to "SGP" glue pot.



OVERVIEW OF TECHNICAL FEATURES

TECHNOLOGICAL ADVANTAGES

HP version

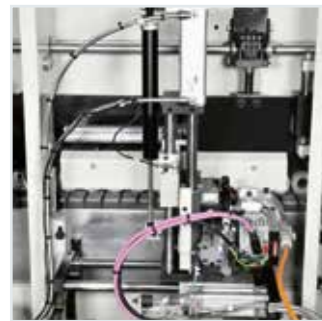

1-motor rounding unit: automatic set up with NC axis for machining different edge thicknesses.

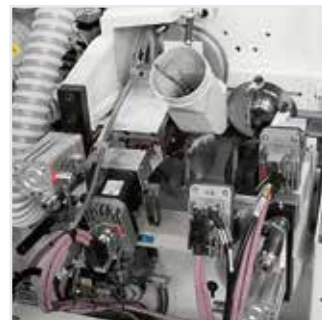

RAS-HP Multiedge 2R edge scraping unit.

Multiedge units: rapid machining changeover between 2 different radii, infinite thin edges and solid wood.



R-HP Multiedge 2R trimming unit.



Pressure roller conveyor with electronic positioning and timed intervention.

MAESTRO active edge: an expert operator that guides you to produce quickly and without errors. 21,5" Touchscreen.



Easy size: infeed guide with axis for the NC adjustment of the material removing of the pre-milling unit.



SGP-E glue pot: homogeneous application of the glue on all materials.



OVERVIEW OF TECHNICAL FEATURES

TECHNOLOGICAL ADVANTAGES



R-K trimming unit: rapid machining changeover between thin, thick and solid wood edges.



K-2 Radius end cutting unit: cut and radius in a single operation.



RC-N glue scraping unit: it eliminates any excess of glue on the panel/edge junction. Nesting machining.



RAS-V edge scraping unit: perfect radius on plastic edges.



ROUND 1 rounding unit: rounding of corners on straight and shaped panels.



SGP-E glue pot: homogeneous application of the glue on all materials.

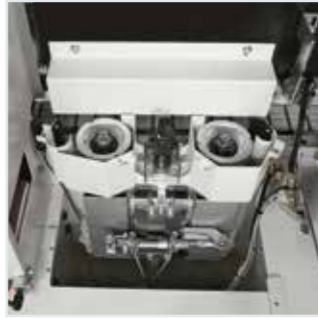

RT-V1 pre-milling unit: a perfect edge joint line.



AAR anti-adhesive unit: the highest level of panel cleaning by applying anti-adhesive spray.

Control Touch 7: a "touch" to use the machine.



OVERVIEW OF TECHNICAL FEATURES

TECHNOLOGICAL ADVANTAGES

k 230 evo



K-2 Radius end cutting unit: cut and radius in a single operation.



RC-N glue scraping unit: it eliminates any excess of glue on the panel/edge junction. Nesting machining.



RAS-V edge scraping unit: perfect radius on plastic edges.



ROUND 1 rounding unit: rounding of corners on straight and shaped panels.



"Orion One Plus" control unit: For a simple, intuitive and error-free use of the machine.



AAR anti-adhesive unit: the highest level of panel cleaning by applying anti-adhesive spray.



RT-V1 pre-milling unit: a perfect edge joint line.



R-K trimming unit: rapid machining changeover between thin, thick and solid wood edges.



SGP-E glue pot: homogeneous application of the glue on all materials.

LIQUIDS FOR PANEL FINISHING

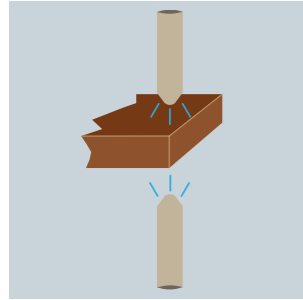

AAR Anti-adhesive device
It prevents the glue residue from adhering to the panels

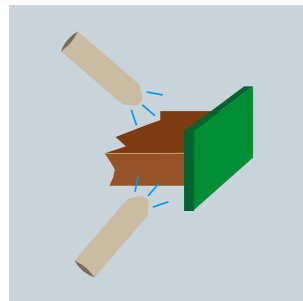

Spray-mist device for the glue cooling
It cools the glue improving the finish of the panel and prevents the glue from sticking to the tools

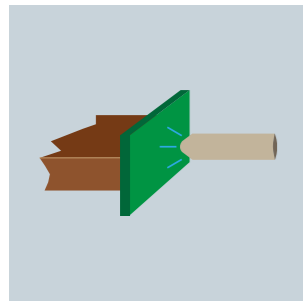

Nebulizing device for delicate edges
It facilitates machining of panels with delicate edges or with protective films

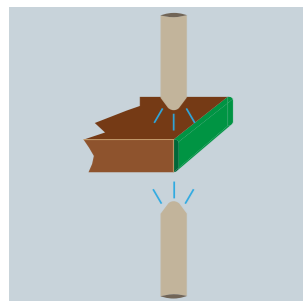

Nebulizing device for edge finishing
It facilitates the finish of plastic edge and brights the colours along with the brushing unit



ENERGY ONLY WHEN NEEDED
SavEnergy allows the operation of the devices only when really necessary. The machine automatically enters stand-by mode when there are no panels to be machined.



WORKING UNITS PRE-MILLING UNITS

olimpic range
automatic edge banders

PERFECT JUNCTION LINE

A perfect surface for the gluing of the edge thanks to 2 large diameter diamond tools (100 mm) and the opposite rotation of 2 high frequency motors. Optimized tool consumption with position adjustment of cutting.



RT-V
k 560



RT-V1
k 230 evo k 360

WORKING UNITS

GLUING UNITS

ALL YOU NEED FOR HIGH QUALITY EDGE BANDING

A complete range of advanced technological solutions.

QMS-P PREMELTING SYSTEM

The best glue quality available at any time, thanks to the premelting device for EVA glue ensuring that “freshly” melted glue is always on hand inside the glue pot.

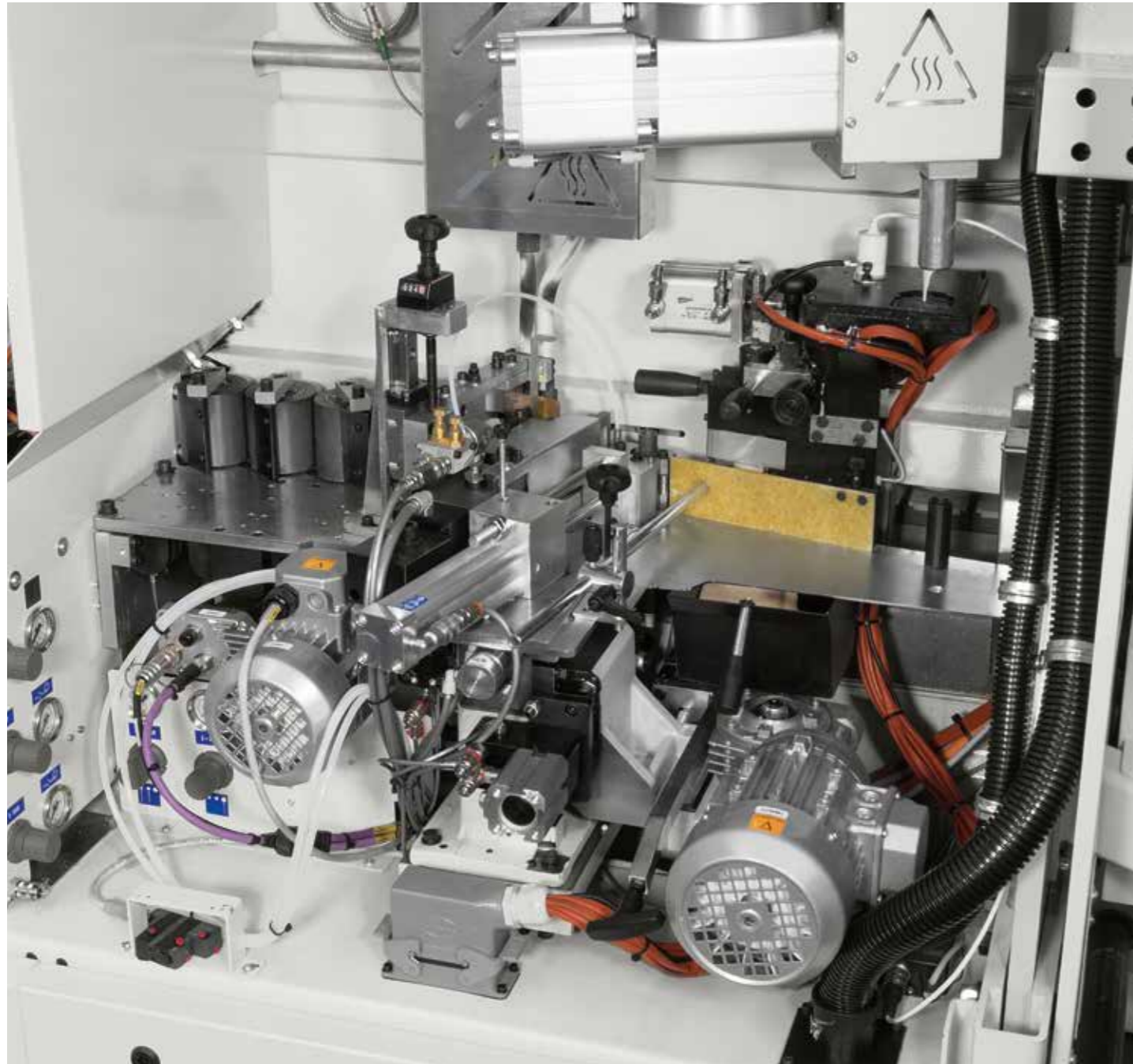

VC - S4.1

k 560



SGP GLUE POT (SMART GLUE POT)

Perfect glue line thanks to a precise adjustment of the glue dosing and to the spreading roller with a special knurling with variable pitch. The use of EVA and Polyurethane glue is made possible by the anti-adherent plasma treatment and a fast and simple glue changeover. Automatic adjustment of the glue dosing with NC axis (opt.)

k 560



AirFusion⁺

by **scm**

AIRFUSION⁺ E DEVICE

“Zero” glue line obtained with the AirFusion⁺, technology that allows edgebanding without glue, thus ensuring that the joint between the edge and the panel is invisible.



k 560

WORKING UNITS GLUING UNITS



SGP-E glue pot:

Versatility and quality at your fingertips

Always the best joint line thanks to a precise glue dosage and a homogeneous glue application. No compromise with the use of EVA and PU glue thanks to a simple and quick glue changeover.



k 230
evo k 360



Kit for machining edges in strips

WORKING UNITS CUTTING UNITS

For a perfect cut of the excess edge on the front and rear side of the panel, always guaranteed by a precise and reliable kinematics in all working conditions.



K/SEL

High finishing quality thanks to the tilting of the blades and the sliding on backlash-free prismatic guides.

k 560



K-1

Double blade unit with independent copying devices.

**k 230
evo**

K-2 RADIUS: CUT AND RADIUS IN A SINGLE OPERATION

The cut with radius of the thick edge is automatically carried out without errors thanks to a special double-blade system.

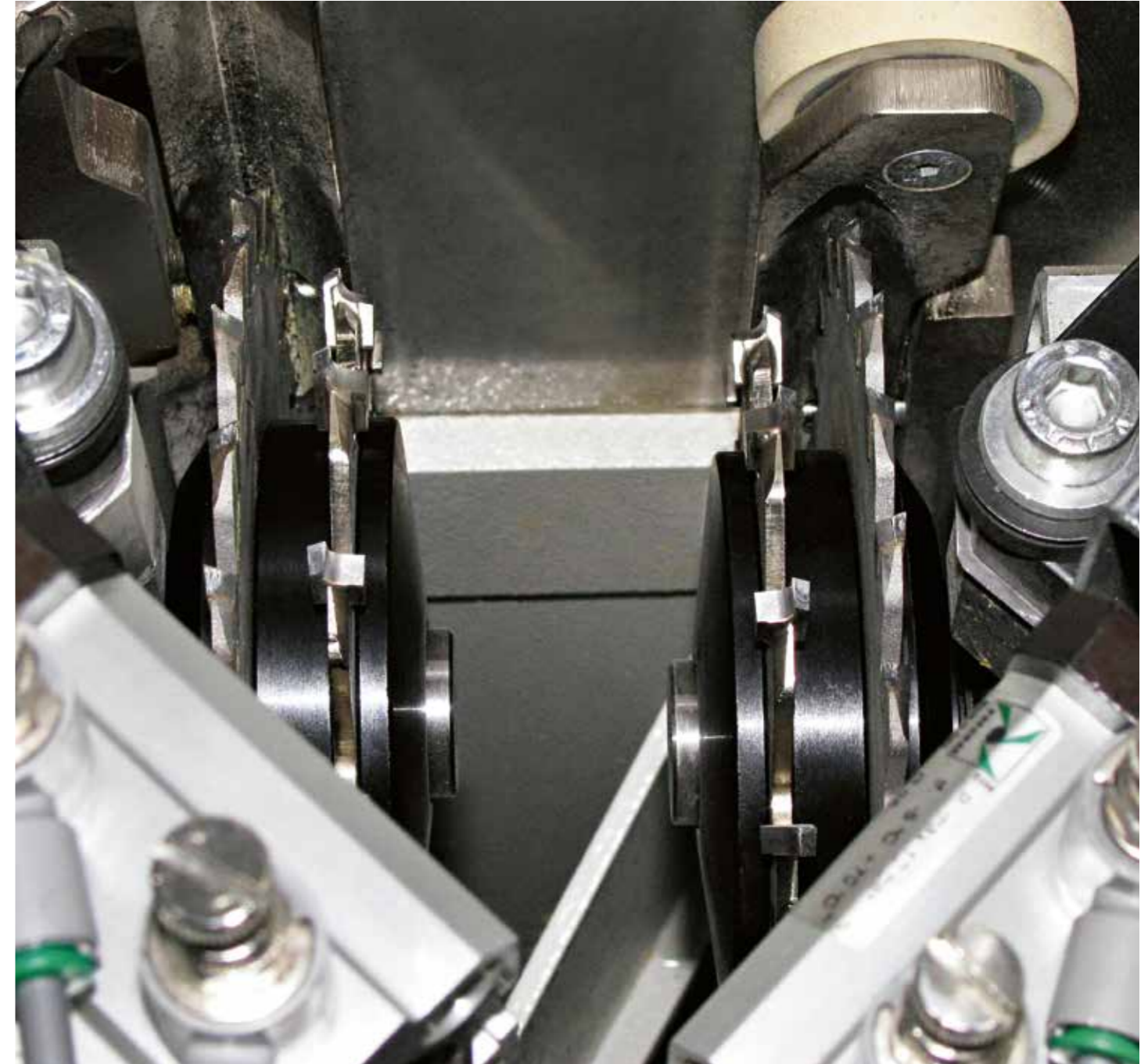

**k 230
evo** **k 360**

WORKING UNITS

TRIMMING UNITS

For trimming the excess edge in the upper and lower sides of the panel with a fast and simple machining changeover between thin, thick and solid wood edges.



R-K

Manual or automatic set up for machining changeover. Vertical and frontal rotating copying devices.



R-HP Multiedge 2R

Fast machining changeover between two different rounded edges, thin and solid wood edges, automatically carried out by 4 NC axes.

Available on hp versions

"COMBI" CUTTER

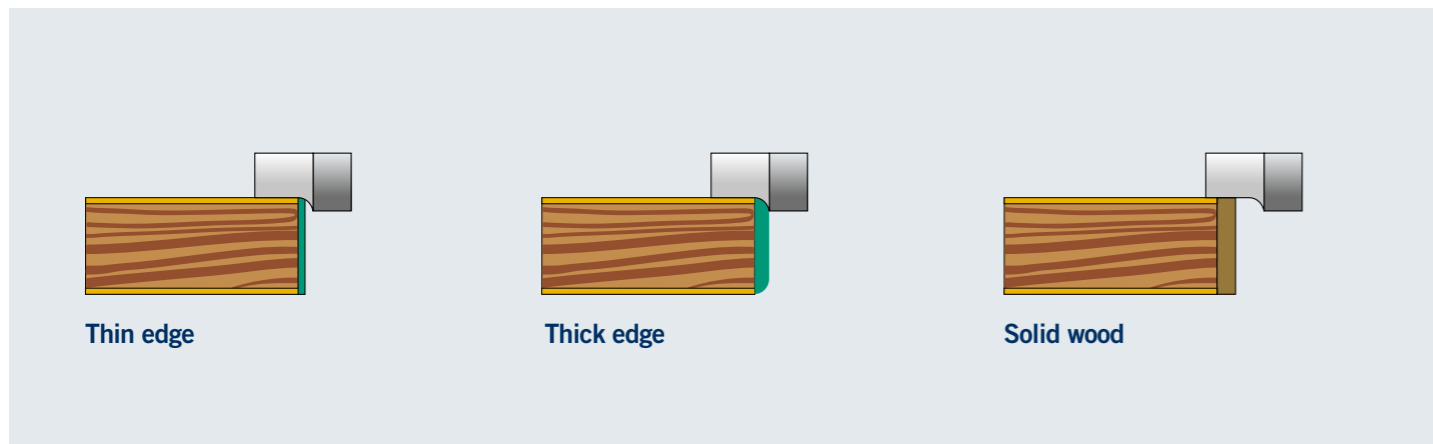

"MULTIEDGE" CUTTER

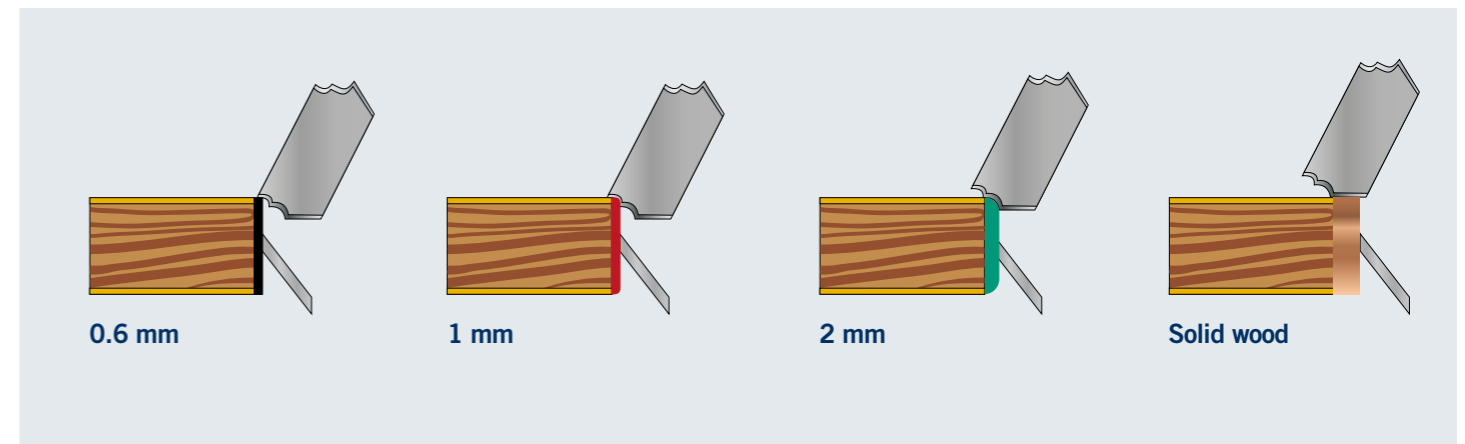

WORKING UNITS

ROUNDING UNITS

For the automatic finishing of corners of straight and shaped panels.

ROUND 1:

Rounding of front and rear angle on straight, chamfered and post-formed panels. The operation is automatically carried out by the unit without requiring further machining.

Automatic set-up with NC axis for machining different edge thicknesses. Available only on HP versions.

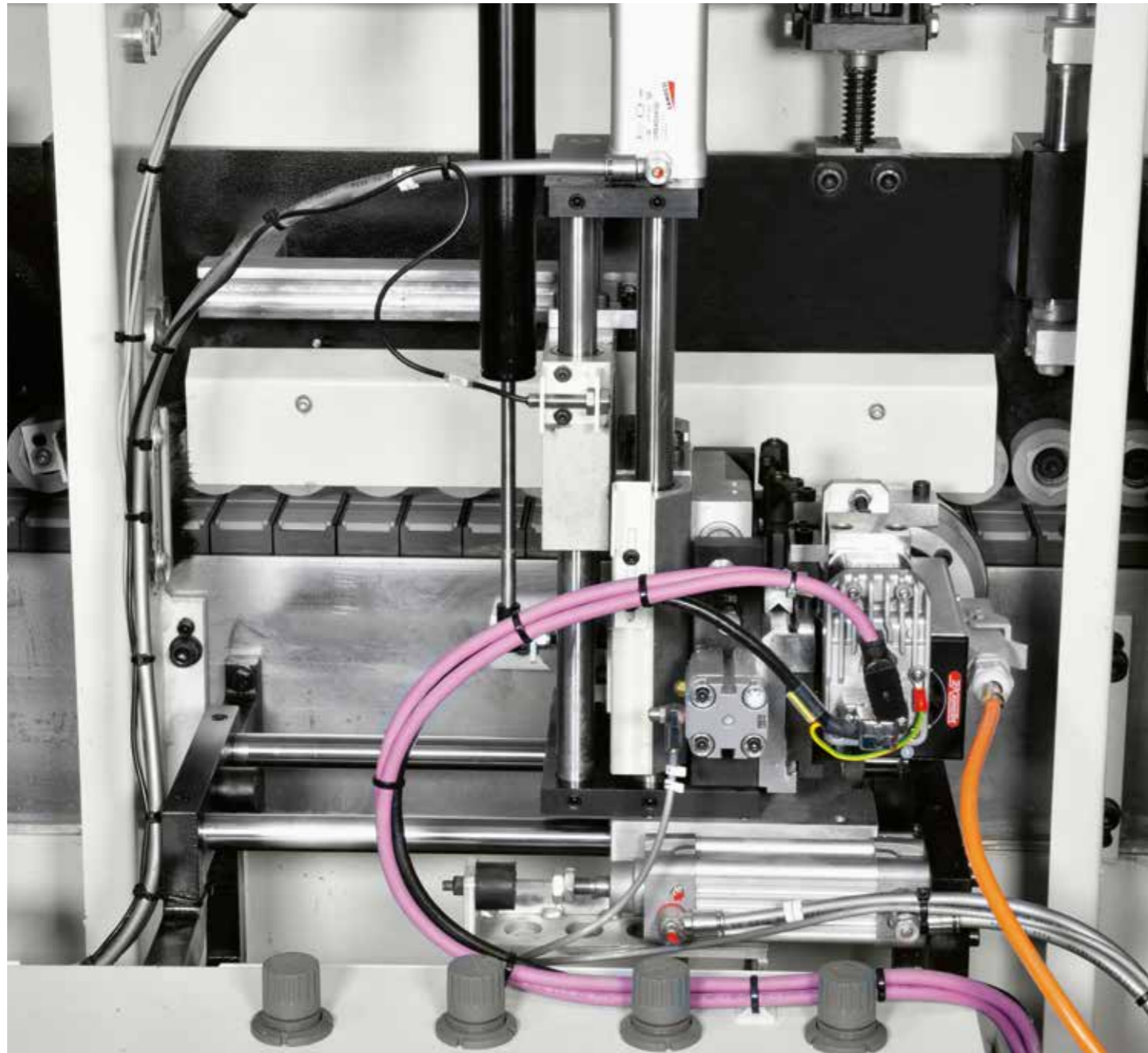

k 230
evo

k 360

ROUND X: PRODUCTIVITY AND QUALITY WITH 2-MOTOR TECHNOLOGY

The features of the unit allow the double function of trimming and rounding of the edge at the same time. The two operations, in a single unit, require less space and, together with the distance between panels of only 600 mm, give a reduction in time for the machining of panels. Automatic set-up with NC axes for machining different edge thicknesses. Available only on HP versions.

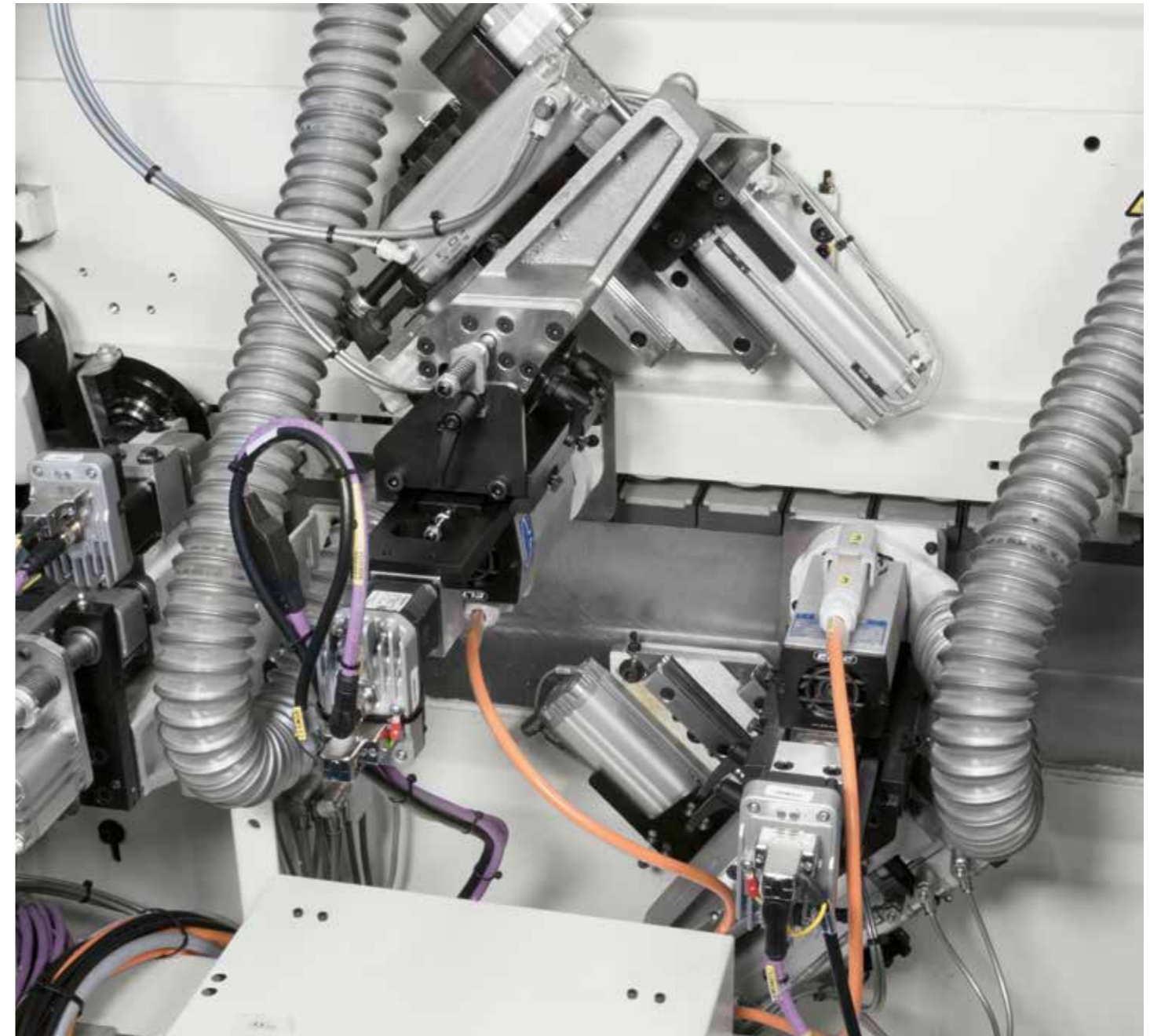

k 560

WORKING UNITS

EDGE SCRAPING UNITS

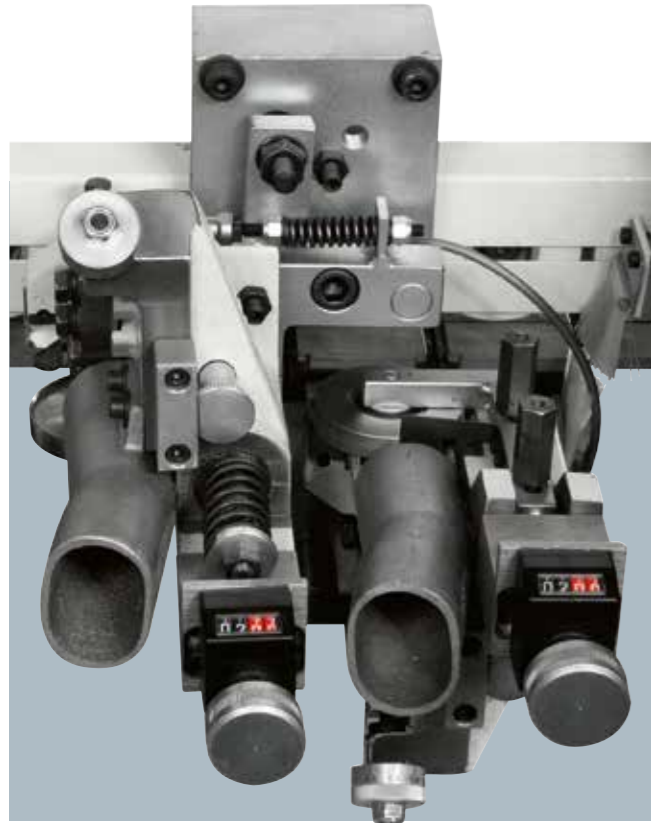

Perfect radius on plastic edges thanks to the complete elimination of the marks left from the tools during trimming operations.

RAS-K
k 560

RAS-V
k 230 evo k 360



RAS-HP Multiedge 2R: 2 different radii on plastic edges

Processing of two different radii with 4-axis NC adjustment.



Available on HP versions

WORKING UNITS

GLUE SCRAPING UNITS

PERFECT JOINT LINE

It eliminates any excess of glue in the joint between panel and edge.

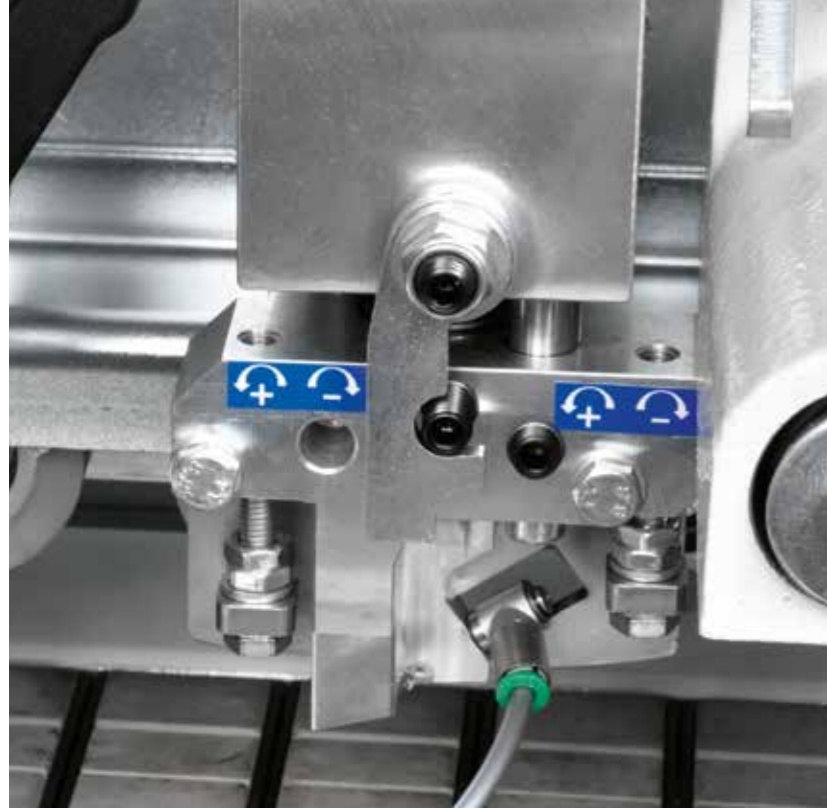

RC-M
k 230
evo

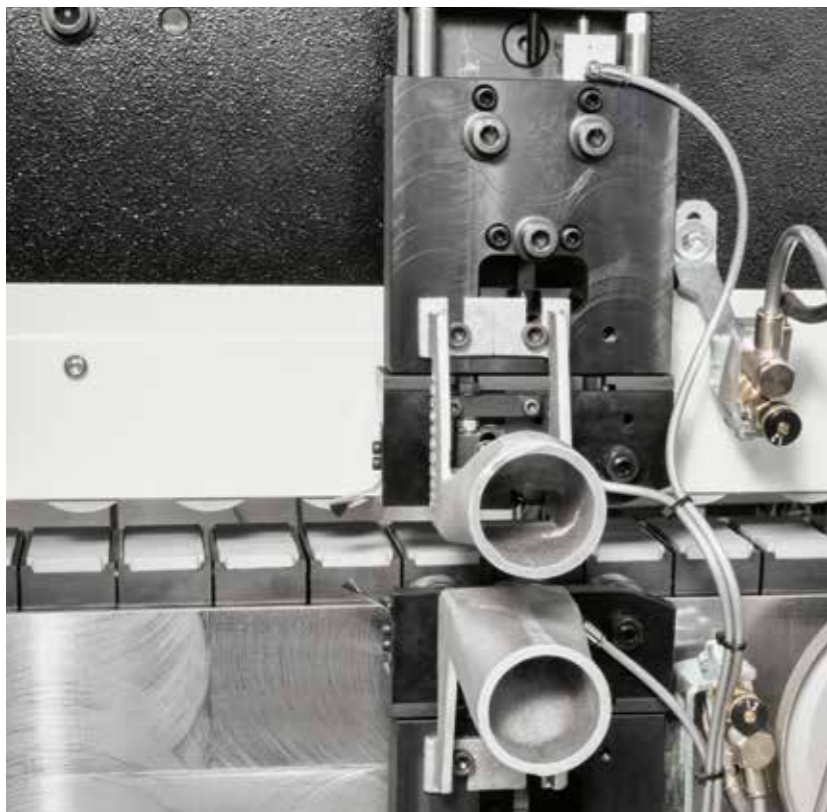

RC-N
Nesting machining.

WORKING UNITS

BRUSHING UNITS

For the cleaning and brightening of the edge.



SP-M
k 230
evo



SP-V
k 360 k 560



Air cushion table

For an easy introduction of the panel into the machine.



Nesting copying devices

Optimal finish of panels with holes for hardware on the upper side thanks to the 3 rotating support points. Available for trimming and edge scraping units.



Easy size

Infeed guide with NC adjustment of the material removing by the premilling unit.

k 360 k 560



Panel spacer device

k 560



FASTBACK 21

Device for the return of the panel to the operator allowing an increase in daily productivity with a single operator in a simple and reliable way, by means of the automatic return of the panel to the loading area of the edge bander.

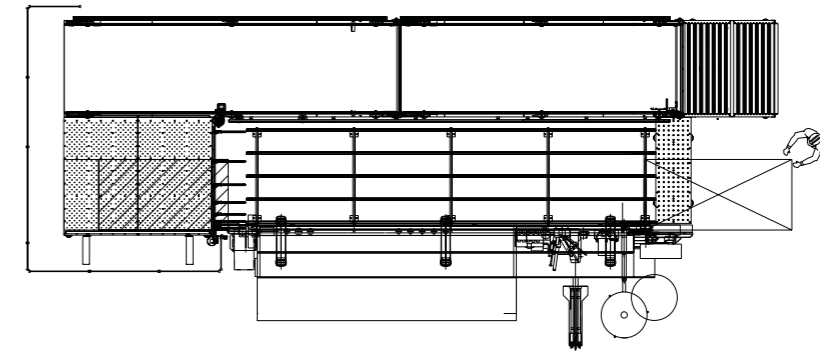

TECHNICAL DATA

	LENGTHWISE FEEDING		CROSSWISE FEEDING		Panel thickness	Maximum panel weight
	Minimum length	Maximum length	Minimum width	Maximum width		
olimpic k 360	250 mm	2100 mm	200 mm	800 mm	8 - 60 mm	40 Kg
olimpic k 560	140 mm	2100 mm	120 mm	800 mm	8 - 60 mm	40 Kg

M Maestro Digital Systems

SMART SOFTWARE AND DIGITAL SERVICES TO ENHANCE PRODUCTIVITY OF WOODWORKING AND FURNITURE INDUSTRIES.

SCM accompanies woodworking companies throughout their whole process combining machines with matching software solutions and digital services, with a constant strive to enhance company productivity.

The software solutions powered by SCM are developed to optimize machine usage as well as the entire process, providing integration with the different software existing in the company.

> programming and data generation

Maestro office

Office

Factory

Maestro active

> edge banding

SOFTWARE

Simple, smart and open. Maestro software are tailored on the machine technology as well as on the entire process. All Maestro software share a common mission:
easy to use, so that any operator can easily and confidently learn and use the software
smart, with algorithms and computing modules aiming at the best possible result
open in order to integrate existing software, and provide customer the coverage of all his process.

DIGITAL SERVICES

Transforming the way it delivers services to its customers through digital technologies and particularly, the IoT platform that collects and analyses data coming from the machine, **SCM created a world of services enabled by Maestro connect.**

Meaning that connecting an SCM machine through Maestro connect will let customer subscribe a program of fast-evolving services and access a wide range of benefits that even go beyond the machine experience and will support and assist you through the whole life-cycle of your machine.

Maestro connect IoT Platform

1 Machine monitoring, KPIs, early warning

2 Maintenance equipment

3 Predictive maintenance

4 Report and historical data export to MES

5 Warranty extension

6 Augmented remote support

7 Smart learning, SELF-HEALING, video tutorials

8 Asset management with e-shop SCM Spare Parts





Maestro edge



Before the production, it is possible to program and generate edge banding programs directly from the office.

SOFTWARE

Office



Maestro active edge

Maestro active is the new operator interface software which has been unified across all SCM technologies. A single operator can easily and confidently run multiple machines due to controller and interface consistency: regardless the machine, Maestro active maintains the same look&feel, with many identical icons and navigation buttons, thus ensuring the same approach to interaction.

EASE OF USE

The new interface has been specifically designed and optimized for immediate use via touch screen. Graphics have been redesigned for simple and comfortable navigation, with tablet-like icons on touch screen controller.

“ZERO” ERRORS

Improved productivity thanks to integrated help and recovery procedures that reduce the possibility of error from the operator’s side.

SOFTWARE

Factory

Maestro edge

PROGRAMMING THE EDGE BANDER DIRECTLY FROM THE OFFICE

FUNCTIONS

- Display of all the information present in Maestro active edge
- Receipt of machine production reports generated by the Maestro active edge
- Remote programming with creation of new edges and tools

With the same interface of Maestro active edge, the office software Maestro edge allows to:

- edit machine programs directly from the office
- recall, view and modify existing programs in the machine

Maestro active edge

A REVOLUTIONARY APPROACH TO INTERACT WITH YOUR SCM MACHINE

FULL CONTROL OF PRODUCTION PERFORMANCES

The creation of customizable reports by operator, shift, program, forecast period (and much more) allows to monitor, optimize and improve the production performance.

FULL MACHINE AWARENESS AND KNOWLEDGE MANAGEMENT SYSTEM

Maestro active allows to record the times related to setup, maintenance, training and other events, tracing all the activities in a database. The operator’s know-how is also stored and made available to other people inside the organization thanks to the possibility to comment and document all production events or notifications.

ORGANIZE YOUR PRODUCTION

Maestro active facilitates the ability to create different users with different roles and authorizations (e.g.: operator, maintainer, administrator, ...). Any user can only execute the functions whose permissions have been assigned to him. It is also possible to define the work shifts on the machine and then detect activities, productivity and events that occurred in each shift.

A WORLD OF SERVICES FOR GREATER EFFICIENCY

Maestro connect

CONNECT YOUR MACHINE AND GAIN ACCESS TO A WORLD OF SERVICES

Connecting your machine through IoT technology, Maestro Connect will let you subscribe a program of fast-evolving services. You will access a wide range of benefits that even go beyond the machine experience and will support and assist you through the whole life-cycle of your machine.

FASTER SERVICE INTERVENTION AND PROBLEM RESOLUTION

Maestro Connect provides real time data and Health Records of the Machine also to SCM Service drastically reducing its troubleshooting time.

DIGITAL SERVICES

SMART MAINTENANCE: DOWN TIME REDUCTION

Maestro Connect reduces maintenance downtime thanks to:

- Automatic maintenance notifications and scheduling, to prevent failures and work in the best conditions of use
- Direct connection to SCM Service thanks to an automatic ticket opening function

SMART MACHINE: ANYTIME, ANYWHERE AWARENESS

Connecting your SCM machine also means having your machine always at hand.

Immediate instant notifications in case of alarms or downtimes allow customers to immediately take an action thus optimizing his productivity.

SMART MANAGEMENT: PRODUCTION PERFORMANCE OPTIMIZATION

Reports and KPIs allow further analysis thus increasing Customer Knowledge about his performance and results.

SMART PARTS: FAST PARTS REPLENISHMENT

Repairs are scheduled proactively since the system provides Spare Parts suggestions and a direct Integration with Smart Parts e-shop.

SMART LEARNING: EXECUTE WORK AND RECEIVE PROBLEM SOLVING SUPPORT

Maestro connect provides an intuitive Problem Solving Management System to help the operator to self solve any issue..

SMARTTECH: FASTER AUGMENTED SUPPORT

Maestro connect allows augmented reality support by means of Smarttech: the head-wearable computers with wireless connectivity that will bring the interaction between customer and SCM service to a higher level.

SMART WARRANTY: YOUR MACHINE ALWAYS IN PERFECT CONDITIONS

Together with scheduled maintenance contracts, you can take care of your asset by doubling the warranty from 1 year to 2 years* for complete peace of mind!

* Please read the complete contract to understand terms and conditions.



JUST A "TOUCH" TO USE THE MACHINE

Intuitive and easy to use thanks to its customized graphics and one touch mode

- **Startouch** display 12"

- **Touch 7** display 7"

k 360 k 560



"ORION ONE PLUS" CONTROL: SIMPLE AND INTUITIVE

The control with its buttons and customised graphics allows an easy and error-free machining.

k 230 evo k 360

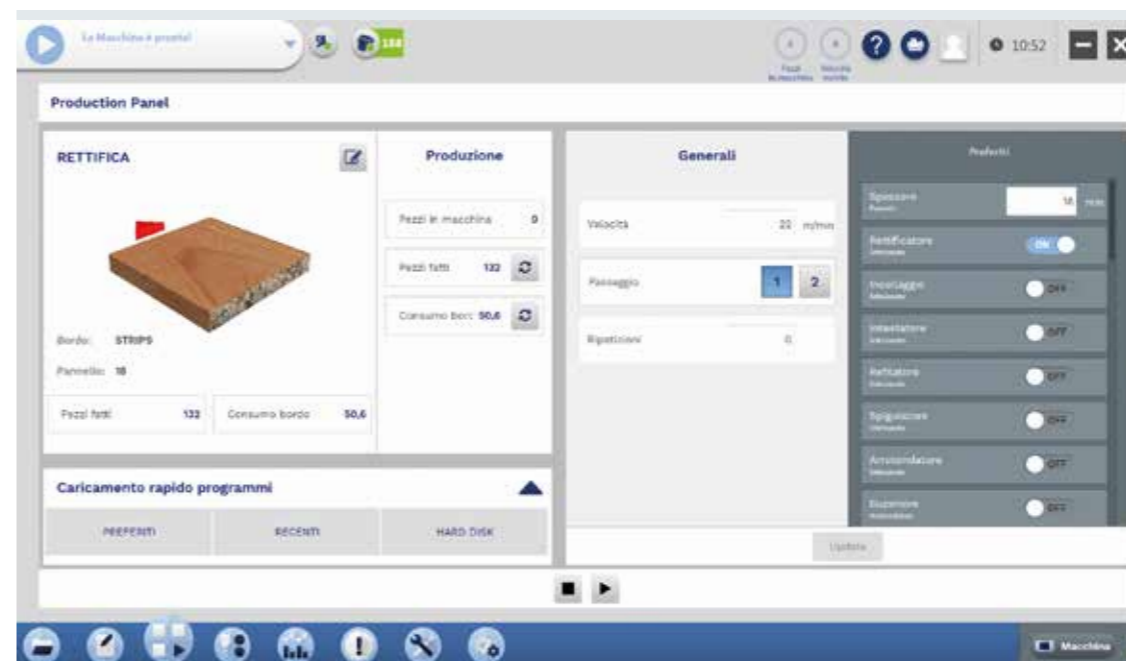

MAESTRO ACTIVE EDGE AND MAESTRO CONNECT: PRODUCING IN SMART MODE

Operator interface with immediate and intuitive panel programming thanks to the adaptive 3D design of the processing with real time preview. Machine connection to a world of services (opt. only for HP versions)

k 360 k 560

COMPOSITIONS

OLIMPIC K 560

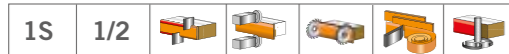
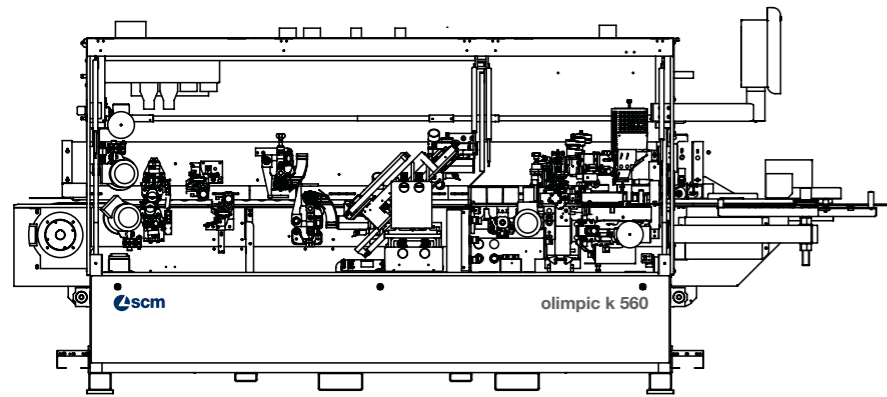

olimpic k 560 E

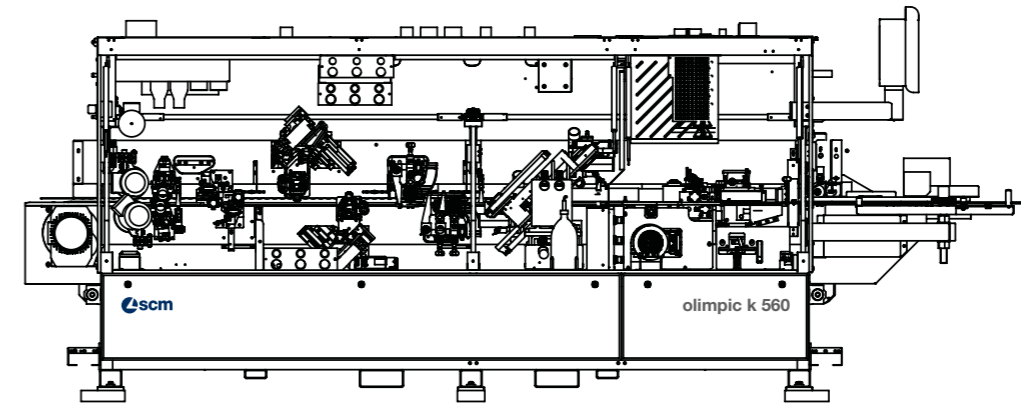

olimpic k 560 ER2

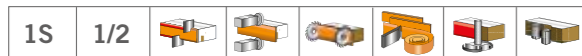
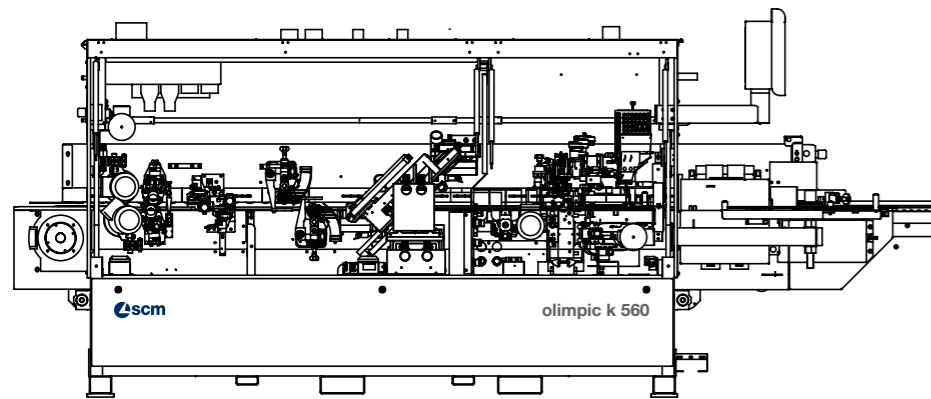

olimpic k 560 T-E

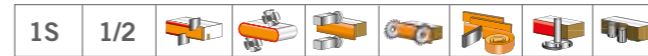
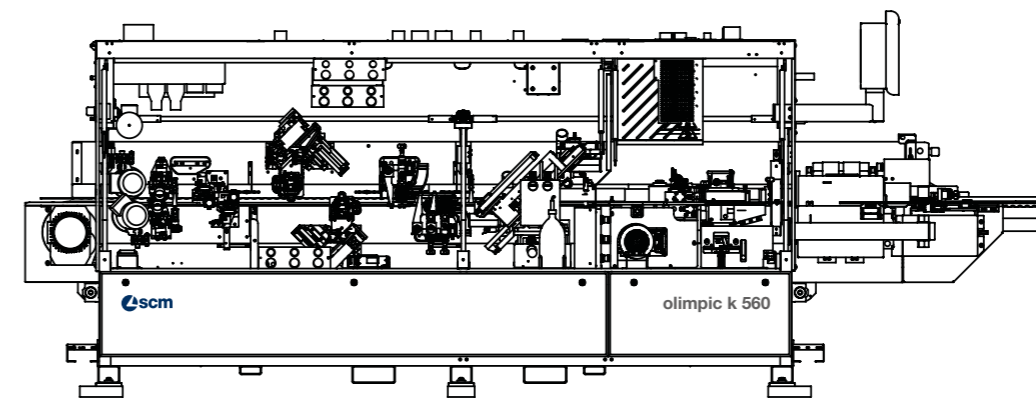

olimpic k 560 T-ER2

Optional units for olimpik k 560



TECHNICAL DATA		E	T-E	ER2	T-ER2	HP T-ER2
Feed speed	m/min			12 - 18		
Panel thickness	mm			8 - 60		
Min. panel width	mm			95 (60)		
Edge thickness	mm	0,4 - 6 (12)	0,4 - 6 (12)	0,4 - 6 (12)	0,4 - 6 (12)	0,4 - 8 (12)
Compressed air	bar			6		
Machine width	mm	3979	4163	4579	4764	4764
Approx. weight	Kg	1250	1400	1620	1750	1840

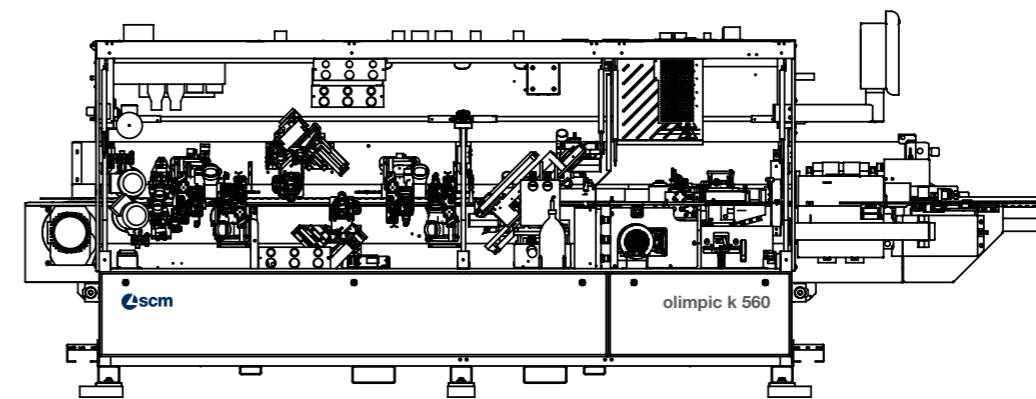

olimpic k 560 HP T-ER2

COMPOSITIONS

OLIMPIC K 360

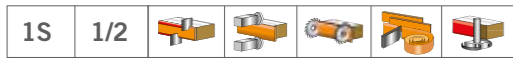
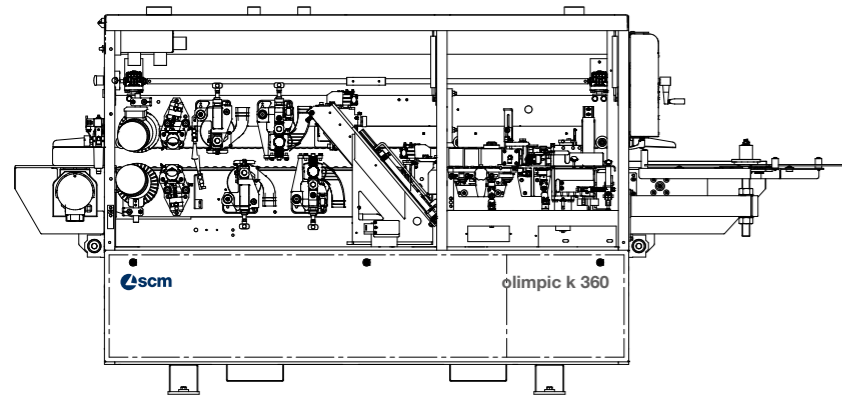

olimpic k 360 E

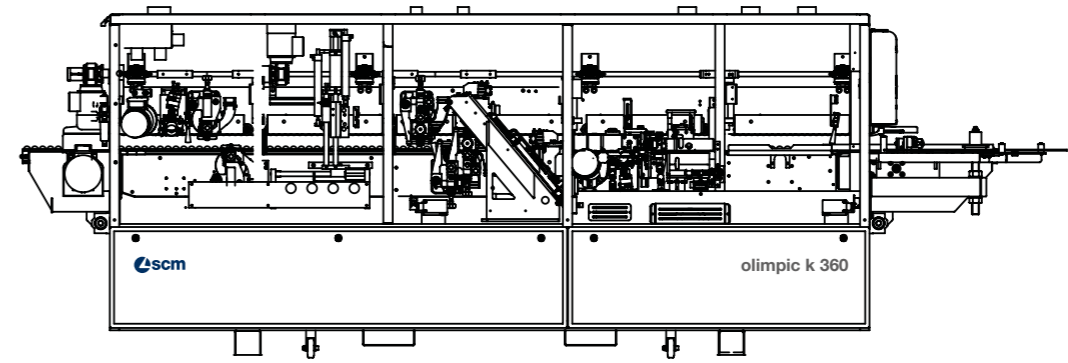

olimpic k 360 ER1

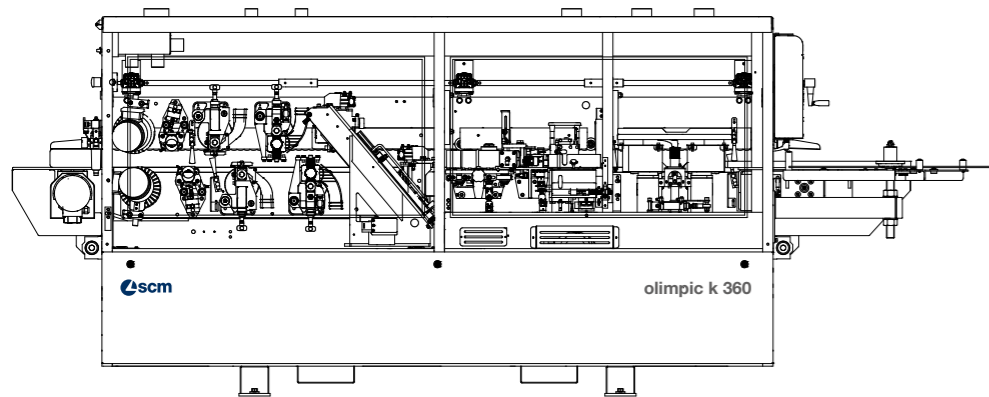

olimpic k 360 T-E

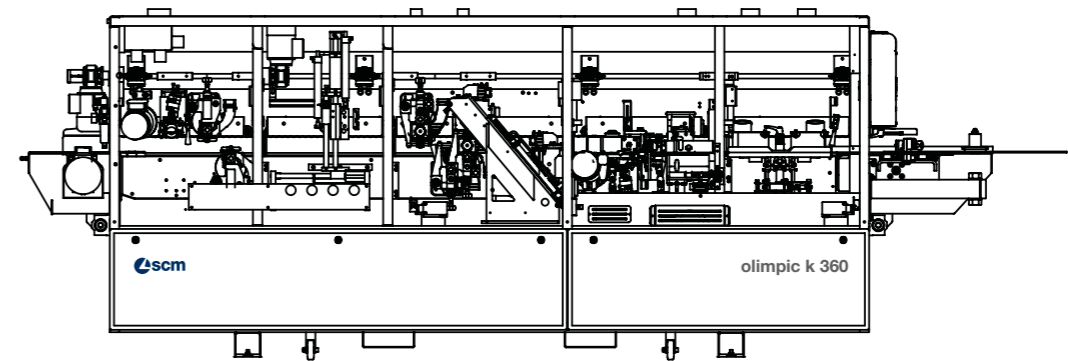

olimpic k 360 T-ER1

Optional units for olympic k 360



TECHNICAL DATA		E	T-E	ER1	T-ER1	HP T-ER1
Feed speed	m/min			11		
Panel thickness	mm			8 - 60		
Min. panel width	mm			90		
Edge thickness	mm			0,4 - 6		
Compressed air	bar			6		
Machine width	mm	3206	3774	4109	4109	4468
Approx. weight	Kg	725	885	1170	1200	1300

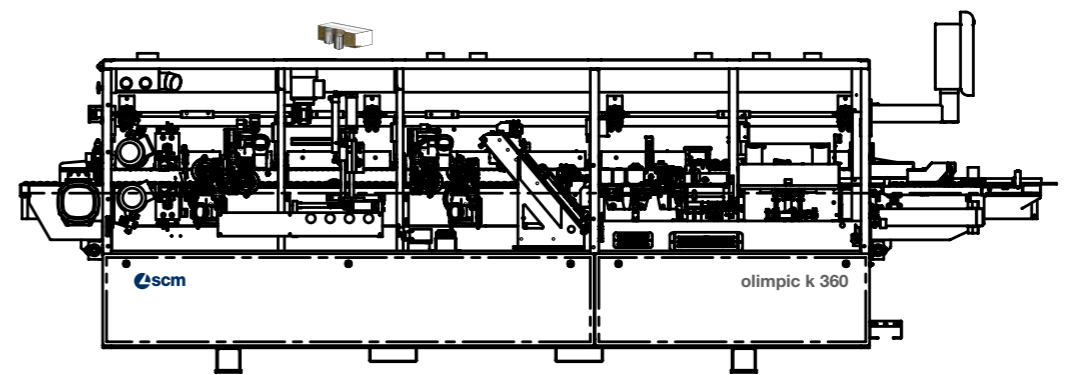

olimpic k 360 HP T-ER1

COMPOSITIONS

OLIMPIC K 230 EVO

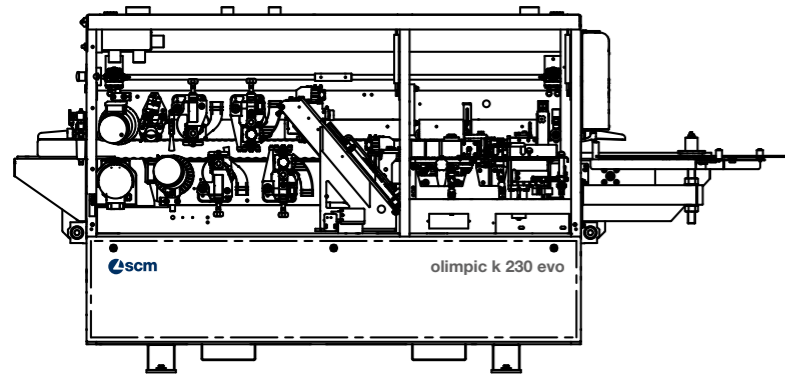

opz.1	1/2	1		
opz.2	1S	RCM	RAS	

olimpic k 230 evo A

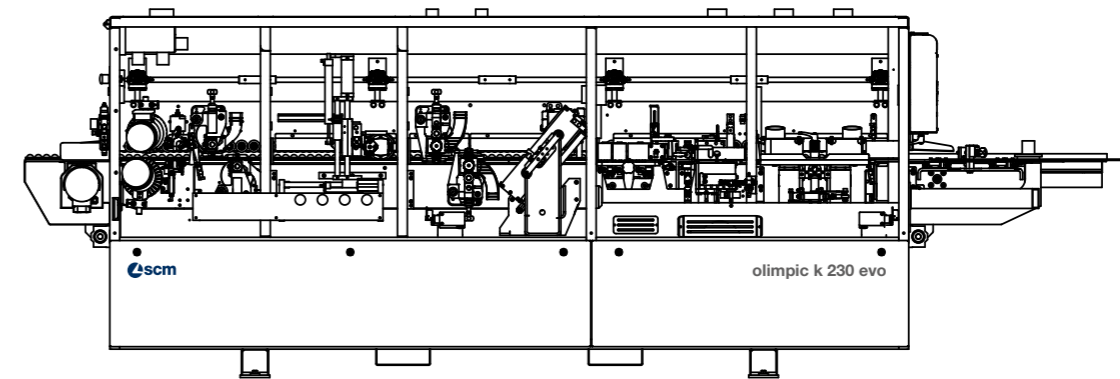

1S	RC						
----	----	--	--	--	--	--	--

olimpic k 230 evo T-ER1

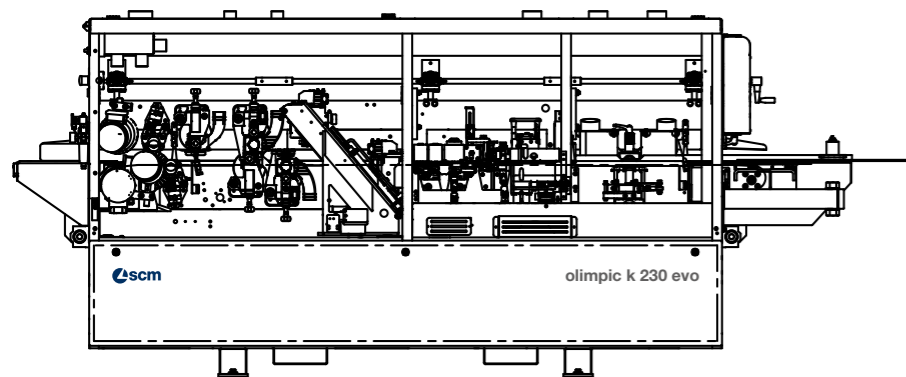

opz.1	1/2	1		
opz.2	1S	RCM	RAS	

olimpic k 230 evo T

Optional units for olimpik k 230 evo

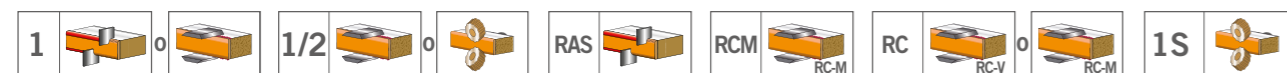

TECHNICAL DATA		A	T	T-ER1
Feed speed	m/min		9	
Panel thickness	mm		8 - 60	
Min. panel width	mm		90	
Edge thickness	mm		0,4-3	
Compressed air	bar		6	
Machine width	mm	3157	3723	4457
Approx. weight	Kg	660	830	1340

Maximum noise levels measured according to the operating conditions established by EN ISO 18217:2015

	olimpic k 230 evo	olimpic k 360	olimpic k 560
Acoustic pressure in process (measured according to EN ISO 11202-2010, uncertainty K≤4 dB)	83 dbA uncertainty K ≤ 4 dB	83 dbA uncertainty K ≤ 4 dB	84 dbA uncertainty K ≤ 4 dB
Acoustic power in process (measured according to ISO 3746-2010, uncertainty K≤4 dB)	98 dbA uncertainty K ≤ 4 dB	98 dbA uncertainty K ≤ 4 dB	99 dbA uncertainty K ≤ 4 dB

Even if there is a correlation between above mentioned "conventional" noise emission values and average levels of personal exposure over eight hours of operators, these last also depend on the real operating conditions, duration of exposure, acoustic conditions of the working environment and presence of further noise sources, this means the number of machines and other adjacent processes.

**COMPANY WITH
QUALITY SYSTEM
CERTIFIED BY DNV GL
= ISO 9001 =**

The technical data can vary according to the requested machine composition. In this catalogue, machines are shown with options. The company reserves the right to modify technical specifications without prior notice; the modifications do not influence the safety foreseen by the EC Norms.

PROMPT AND EXPERT TECHNICAL SUPPORT THROUGH A NETWORK OF 1000 TECHNICIANS AND AN INVENTORY OF 36,000 SPARE PARTS.

HIGHLY SPECIALISED TECHNICIANS, EFFICIENT MANAGEMENT AND 6 SPARE PARTS BRANCHES AROUND THE WORLD GUARANTEE A CLOSE, SAFE AND EFFECTIVE TECHNICAL SUPPORT.

SERVICE

SCM provides a service that goes beyond the purchase, to guarantee the long term performance of your technological production system and peace of mind for your business.

A COMPLETE RANGE OF AFTER-SALES SERVICES

- installation and start-up of machines, cells, lines and systems
- tailored training programs
- telephone support to reduce times and costs when machines are not working
- preventive maintenance programs to guarantee long term performance
- complete renovation of machines and plants to renew the added value of the investments
- custom upgrading to update machines and plants and meet new production requirements

SPARE PARTS

SCM Group can count on 140 spare parts professionals worldwide to meet any request with real time shipments.



36,000 SPARE PARTS

Our spare parts inventory, with a value of 12 million euros, covers every single machine



SPARE PARTS GUARANTEED

We guarantee also hard to find parts, with 3,5 million euros invested in "critical" spare parts.



IMMEDIATE AVAILABILITY

Over 90% of orders received are carried out the same day thanks to the huge inventory available.



6 BRANCHES AROUND THE WORLD

The spare parts service can count on worldwide support (Rimini, Singapore, Shenzhen, Moscow, Atlanta, São Bento do Sul)



500 SHIPMENTS A DAY

THE STRONGEST WOOD TECHNOLOGIES ARE IN OUR DNA

SCM. A HERITAGE OF SKILLS IN A UNIQUE BRAND

Over 65 years of success gives SCM the centre stage in woodworking technology. This heritage results from bringing together the best know-how in machining and systems for wood-based manufacturing. SCM is present all over the world, brought to you by the widest distribution network in the industry.

65 years history

3 main production sites in Italy

300.000 square metres of production space

20.000 machines manufactured per year

90% export

20 foreign branches

400 agents and dealers

500 support technicians

500 registered patents

In SCM's DNA also strength and solidity of a great Group. The SCM Group is a world leader, manufacturing industrial equipment and components for machining the widest range of materials.

SCM GROUP, A HIGHLY SKILLED TEAM EXPERT IN INDUSTRIAL MACHINES AND COMPONENTS

INDUSTRIAL MACHINERY

Stand-alone machines, integrated systems and services dedicated to processing a wide range of materials.



WOODWORKING TECHNOLOGIES



TECHNOLOGIES FOR PROCESSING COMPOSITE MATERIALS, ALUMINIUM, PLASTIC, GLASS, STONE, METAL

INDUSTRIAL COMPONENTS

Technological components for the Group's machines and systems, for those of third-parties and the machinery industry.



SPINDLES AND TECHNOLOGICAL COMPONENTS



ELECTRIC PANELS



METALWORK



CAST IRON

